

# DATA SHEET

## **SC4000** Universal Timeslot Interchange

Preliminary specification  
File under Integrated Circuits

2000 Sep 07

# Universal Timeslot Interchange

# SC4000

<b>Features</b> .....	1
<b>Applications</b> .....	1
Logic Pin Organization .....	1
Block Diagram .....	2
SC4000 100-Pin TQFP (top view) .....	2
SC4000 Physical Dimensions (all dimensions in millimeters) .....	3
<b>Pin Description</b> .....	4
<b>Device Overview</b> .....	6
<b>Function Description</b> .....	8
Switching .....	8
PLL Timing and Clock Control .....	8
Interrupts Control .....	9
CLKFAIL Timing and Control .....	11
Message Channel Interface .....	11
Operation Mode and Configuration Register Setup .....	11
Register Access Schemes .....	16
<b>Microprocessor Interface</b> .....	17
I/O Address Map .....	17
Busy (D_0) (Read Only) .....	17
Read (D_1) (Write only) .....	17
Write (D_2) (Write only) .....	17
Terminate (D_3) (Read/Write) .....	17
Channel Bank Select Register [1:0] (D_[5:4]) (Read/Write) .....	17
Channel Bank Select Register Enable (D_6) (Write only) .....	17
Reset (D_7) (Read/Write) .....	18
Channel Specific Registers .....	19
Time-Slot Select [6:0] (Read/write) .....	20
Port Select [3:0] (Read/Write) .....	20
Parallel Access Enable (Read/Write) .....	20
Switch Output Enable (Read/Write) .....	20
Time-Slot/Channel Select [6:0] (Read/Write) .....	20
Port Select [3:0] (Read/Write) .....	20
Local Connect Enable (Read/Write) .....	20
Switch Output Enable (Read/Write) .....	20
Parallel Access .....	20
Serial Data [1:8] (Read/Write) .....	20
Source Parallel Access .....	20
Serial Data [1:8] (Read Only) .....	20

## Universal Timeslot Interchange

## SC4000

<b>Configuration Registers</b> .....	21
SCbus Clock Master (C_0) (Read/Write) .....	21
SCbus Clock Master Arm (C_1) (Read/Write) .....	21
SCbus Primary/Alternate Select (C_2) (Read/Write) .....	21
Diagnostic Mode Enable (C_3) (Read/Write) .....	21
SCbus Framing Mode [1:0](C_[5:4]) (Read/Write) .....	21
Local bus Framing Mode [1:0](C_[7:6]) (Read/Write) .....	21
Master Clock Input Frequency Select [2:0] (C_[10:8]) (Read/Write) .....	21
Direct R/W to Parallel Access Registers Enable (C_11) (Read/Write) .....	21
Message Channel Registered TXD Enable (C_12) (Read/Write) .....	21
Message Channel TXD_0 or TXD_1 Select (C_13) (Read/Write) .....	22
Message Channel Clock Duty Cycle Select (C_14) (Read/Write) .....	22
Message Channel Output Disable (W/ loopback) (C_15) (Read/Write) .....	22
SCbus SD Sample Position (C_16) (Read/Write) .....	22
Local Bus SI Sample Position (C_17) (Read/Write) .....	22
SCbus SD Output Delay Enable (C_18) (Read/Write) .....	22
Local bus SO Output Delay Enable (C_19) (Read/Write) .....	22
SCbus FSYNCR Sample Position (C_20) (Read/Write) .....	22
SCbus FSYNCR Rate (C_21) (Read/Write) .....	22
SCbus SCLKX2N, SCLKX2NA Output Disable(C_22) (Read/Write) .....	22
SCbus Alternate ("A") Signals Output Enable (C_23) (Read/Write) .....	23
Local bus L_CLK Polarity (C_24) (Read/Write) .....	23
Local bus L_FS Polarity (C_25) (Read/Write) .....	23
Local bus L_FS Position (C_[27:26]) (Read/Write) .....	23
Local bus L_CLK & L_FS Rate (C_28) (Read/Write) .....	23
Local bus L_CLK DPLL Enable (C_29) (Read/Write) .....	23
Local bus L_CLK 8.192 MHz 62.5% Duty Cycle (C_30) (Read/Write) .....	23
Version/Revision Status (C_[39:32]) .....	23
Master PLL Reference Select [2:0] (C_[42:40]) (Read/Write) .....	23
Internal/External Master PLL Select (C_43) (Read/Write) .....	24
SCbus SREF_8K Source Select [1:0] (C_[45:44]) (Read/Write) .....	24
SCbus SREF_8K Output Enable (C_46) (Read/Write) .....	24
SCbus SCLK 8.192 MHz 62.5% Duty Cycle (C_47) (Read/Write) .....	24
Clock Watchdog Enable (C_48) (Read/Write) .....	24
Microprocessor Watchdog Enable (C_49) (Read/Write) .....	24
SCbus CLKFAIL Latch Set Polarity Select (C_50) (Read/Write) .....	24
SCbus CLKFAIL Latch Debounce Enable (C_51) (Read/Write) .....	24
Frame Boundary Latch Set Delay Enable (C_52) (Read/Write) .....	25
INT_0 Mask_N (C_53) (Read/Write) .....	25
INT_0 Output Polarity (C_54) (Read/Write) .....	25
INT_0 Output Driver (C_55) (Read/Write) .....	25
SCbus CLKFAIL Latch (C_56) (Read Only) .....	25
Frame Boundary Latch (C_57) (Read only) .....	25

# Universal Timeslot Interchange

# SC4000

Internal Master PLL Error Latch (C_58) (Read Only) .....	25
SCbus Error Indicator (C_59) (Read Only) .....	25
SCbus CLKFAIL Latch Clear_N (C_60) (Read/Write) .....	25
Frame Boundary Latch Clear_N (C_61) (Read/Write) .....	25
Internal Master PLL Error Latch Clear_N (C_62) (Read/Write) .....	25
SCbus SCLKX2N Error Latch (C_64) (Read Only) .....	25
SCbus SCLKX2NA Error Latch (C_65) (Read only) .....	26
SCbus SCLK Error Latch (C_66) (Read only) .....	26
SCbus SCLKA Error Latch (C_67) (Read only) .....	26
SCbus SCLKX2N Error Latch Clear_N (C_68) (Read/Write) .....	26
SCbus SCLKX2NA Error Latch Clear_N (C_69) (Read/Write) .....	26
SCbus SCLK Error Latch Clear_N (C_70) (Read/Write) .....	26
SCbus SCLKA Error Latch Clear_N(C_71) (Read/Write) .....	26
SCbus FSYNCN Error Latch (C_72) (Read Only) .....	26
SCbus FSYNCNA Error Latch (C_73) (Read Only) .....	26
SCbus Clock Master Error Latch (C_74) (Read Only) .....	26
SCbus FSYNCN Error Latch Clear_N (C_76) (Read/Write) .....	26
SCbus FSYNCNA Error Latch Clear_N (C_77) (Read/Write) .....	26
SCbus Clock Master Error Latch Clear_N (C_78) (Read/Write) .....	26
SCbus SREF_8K NE SREF_8KA Error Latch (C_80) (Read only) .....	27
SCbus CLKFAIL NE CLKFAILA Error Latch (C_81) (Read only) .....	27
SCbus MC NE MCA Error Latch (C_82) (Read only) .....	27
SCbus SD Error Indicator (C_83) (Read only) .....	27
SCbus SREF_8K NE SREF_8KA Error Latch Clear_N (C_84) (Read/Write) .....	27
SCbus CLKFAIL NE CLKFAILA Error Latch Clear_N (C_85) (Read/write) .....	27
SCbus MC NE MCA Error Latch Clear_N (C_86) (Read/Write) .....	27
SCbus SD Error Latch Clear_N (C_87) (Read/Write) .....	27
SCbus SD_[15:0] Error Latch (C_[103:88]) (Read only) .....	27
<b>Summary of SC4000 Configuration Registers</b> .....	27
Miscellaneous .....	27
Master Clock/PLL .....	27
SCbus (MVIP Bus) .....	27
Local Bus .....	28
Message Channel .....	28
Watchdog .....	28
Interrupt .....	28
Reserved Bit .....	28
<b>Typical Internal Register Access</b> .....	28
Typical Write Internal Register Access .....	28
Typical Read Internal Register Access .....	28
Test .....	29
<b>Electrical Specifications</b> .....	30
<b>AC Electrical Characteristics</b> .....	31

---

 Universal Timeslot Interchange

## SC4000

---

<b>Table 1.</b>	Configuration Register Setup for SCbus Clock Slave .....	11
<b>Table 2.</b>	Configuration Register Setup for SCbus Clock Master.....	12
<b>Table 3.</b>	Configuration Register Setup for SCbus Armed Clock Master.....	13
<b>Table 4.</b>	Configuration Register Setup for MVIP Clock Master .....	14
<b>Table 5.</b>	Configuration Register Setup for MVIP Clock Slave.....	14
<b>Table 6.</b>	SCbus/MVIP Signals Cross Reference.....	15
<b>Table 7.</b>	Microprocessor Interface Timing - Intel Bus Mode .....	31
<b>Table 8.</b>	Microprocessor Interface Timing - Intel Bus Mode .....	32
<b>Table 9.</b>	Microprocessor Interface Timing - Multiplexed Address .....	33
<b>Table 10.</b>	Local Bus Timing, 1X L_CLK Mode (C_28=0) .....	34
<b>Table 11.</b>	Local Bus Timing, 2X L_CLK Mode (C_28=1) .....	35
<b>Table 12.</b>	SCbus Timing .....	36
<b>Table 13.</b>	SCbus Clock Master Timing .....	38
<b>Table 14.</b>	SCbus Clock Fail Timing .....	39
<b>Table 15.</b>	REF_8K_[3:0] and SREF_8K Timing .....	40

---

# Universal Timeslot Interchange

SC4000

---

<b>Figure 1.</b>	Destination and Source Switch Function Block .....	7
<b>Figure 2.</b>	Internal Master PLL (C_43 = 0) Function Block .....	8
<b>Figure 3.</b>	External Master PLL (C_43 = 1) Function Block .....	9
<b>Figure 4.</b>	Internal PLL and Local Bus PLL Timing Function Block .....	10
<b>Figure 5.</b>	Using Two Pins A_[1:0] for Address Bus Interface Scheme (C_11 = 0) .....	16
<b>Figure 6.</b>	Using Nine Pins A_[8:0] for Address Bus Interface Scheme (C_11 = 1) .....	16
<b>Figure 7.</b>	Microprocessor Interface Timing - Intel Bus Mode (Pin I_N = 0), Non-Multiplexed Address .....	31
<b>Figure 8.</b>	Microprocessor Interface Timing - Motorola Bus Mode (Pin I_N = 1), Non-multiplexed Address .....	32
<b>Figure 9.</b>	Microprocessor Interface Timing - Multiplexed Address .....	33
<b>Figure 10.</b>	Local Bus Timing, 1XL_CLK Mode (C_28=0) .....	34
<b>Figure 11.</b>	Local Bus Timing, 2X L_CLK Mode (C_28=1) .....	35
<b>Figure 12.</b>	SCbus Timing .....	36
<b>Figure 13.</b>	SCbus Clock Master Timing .....	38
<b>Figure 14.</b>	SCbus Clock Fail Timing .....	39
<b>Figure 15.</b>	REF_8K_[3:0] and SREF_8K input mode Timing .....	40

# Universal Timeslot Interchange

# SC4000

### FEATURES

- Timeslot interchange between local and expansion buses
- Architecture optimized for call processing environments: SCbus™, MVIP® and ST-BUS Compatible
- Full switching between any of:
  - 128 local bus input SI timeslots
  - 128 local bus output SO timeslots
  - up to 2048 expansion bus SD timeslots
- Multiple local bus speeds and formats:
  - 2.048, 4.096 or 8.192 Mb/s
  - PEB®, STbus or GCI

- Supports both Intel® and Motorola® processor interfaces
- Serial or parallel access to expansion bus
- Enhanced input hysteresis threshold
- Internal phased lock loop
- Fast response and support for SCbus clock fallback
- Flexible local frame sync interface
- Supports hyper channel capability (bundling)
- SCbus message bus interface and local loopback control
- High availability and self-diagnostic features

- 5V CMOS technology
- 100-pin TQFP package

### APPLICATIONS

- PC-based switching
- Small to medium size digital switch matrices
- SCbus/MVIP interface functions
- Digital centralized voice processing system
- Voice/Data multiplexer and exchange
- Computer telephony interface

### Logic Pin Organization

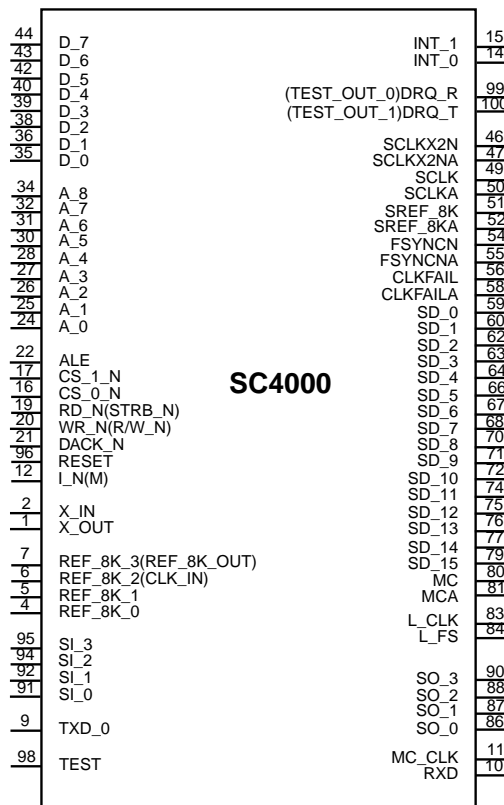

# Universal Timeslot Interchange

# SC4000

## Block Diagram

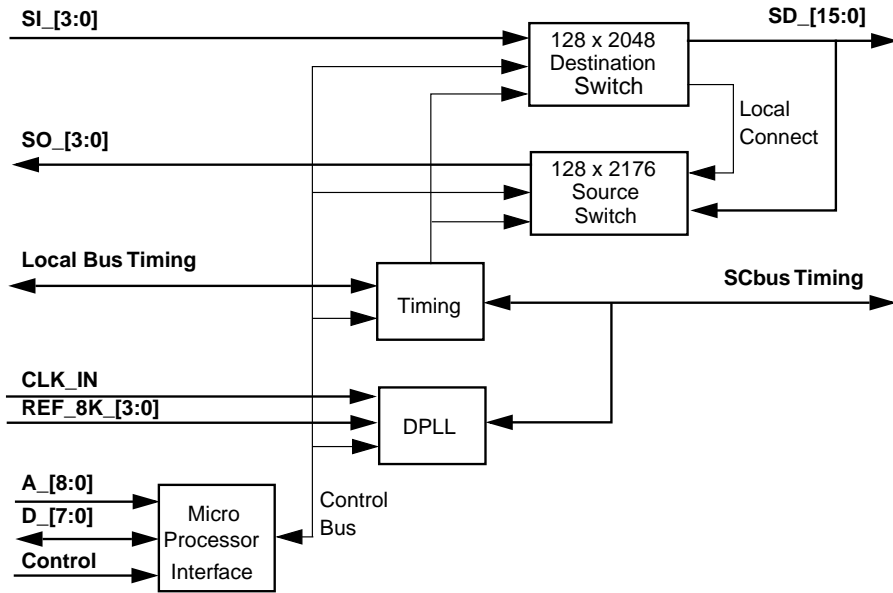

## SC4000 100-Pin TQFP (top view)

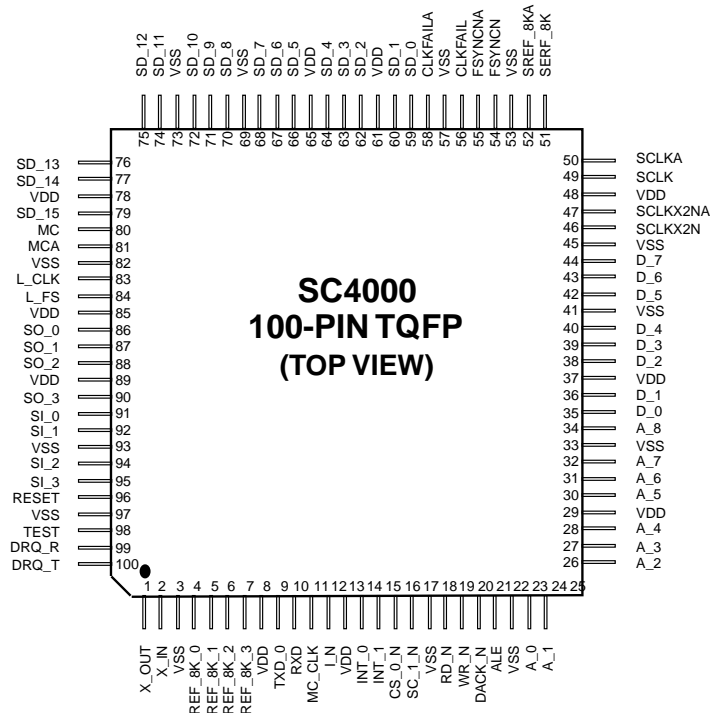



# Universal Timeslot Interchange

# SC4000

SC4000 Physical Dimensions (all dimensions in millimeters)

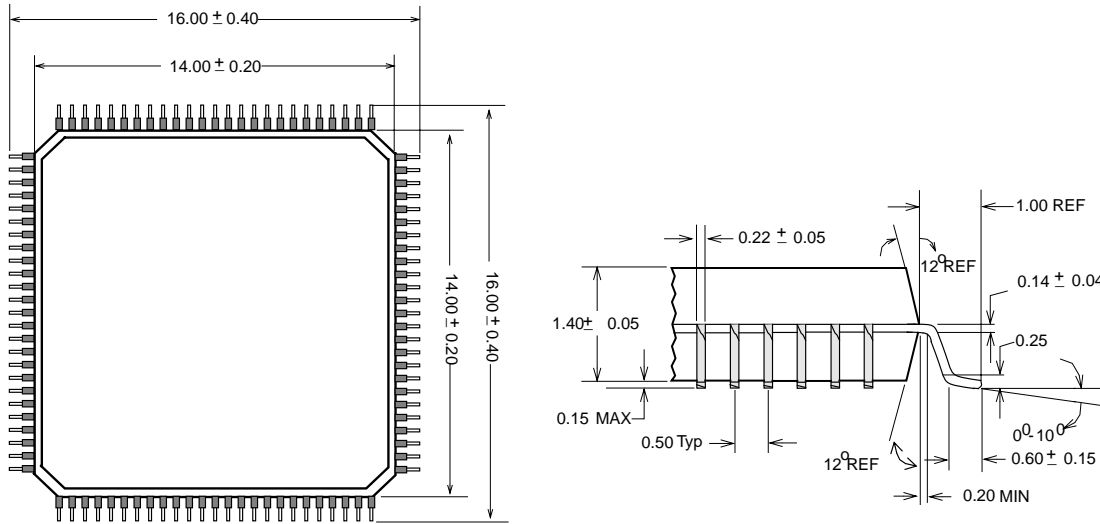

# Universal Timeslot Interchange

# SC4000

## PIN DESCRIPTION

Pin Name	Input/Output	Pin Number	Pin Description
D_[7:0]	I/O	44,43,42,40, 39,38,36,35	(TTL Bi-directional) Microprocessor Data Bus. These bi-directional, tri-state lines allow the microprocessor to access SC4000 internal registers as well as the source/destination routing memory and parallel access registers.
A_[8:0]	I	34,32,31,30, 28,27,26,25,24	(TTL Input) Microprocessor Address Bus. These inputs select the internal registers used by a read or write operation. Normally these inputs are connected to Microprocessor address lines A[8:0].
ALE	I	22	(TTL Input) Address Latch Enable. This input pin is tied to high in non-multiplexed mode. Otherwise, in multiplexed mode, the Microprocessor Address Bus is latched internally on the falling edge of this signal.
CS_1_N	I	17	(TTL Input) Chip Select 1. Reserved for future internal HDLC controller. If unused, this pin should be connected to high.
CS_0_N	I	16	(TTL Input) Chip Select 0. This active low signal selects the SC4000 for a microprocessor read or write operation.
I_N or M	I	12	(TTL Input) Microprocessor Bus Interface Mode Select. When this input is low, Intel Bus Mode (I_N) is selected. When this input is high, Motorola Bus (M) Mode is selected.
RD_N or STRB_N	I	19	(TTL Input) In Intel Bus Mode (RD_N), this active low input operates with CS_0_N to configure the data bus lines D_[7:0] as output. In Motorola Bus Mode (STRB_N), this active low input operates with CS_0_N to enable a read or write operation.
WR_N or RW_N	I	20	(TTL Input) In Intel Bus Mode (WR_N), when CS_0_N is active, the rising edge of WR_N is used to latch an internal data register with data provided via the data bus lines D_[7:0]. In Motorola Bus Mode (RW_N), this RW_N input is used to distinguish between read or write during a microprocessor access.
DACK_N	I	21	(TTL Input, Pull up) DMA Acknowledge Reserved for future internal HDLC controller. If unused, this pin should be left unconnected
RESET	I	96	(TTL Input) Reset. This active high signal initializes the microprocessor interface, configuration, routing and parallel access registers.
X_IN	I	2	(CMOS Input) Crystal Clock Input. This pin is a CMOS level input of either 2.048, 4.096, 8.192, 16.384, 32.768 or 65.536 MHz. A crystal of 16.384 MHz from X_IN to X_OUT may also be used.
X_OUT	O	1	(CMOS Output) Crystal Clock Output.
REF_8K_3 or REF_8K_OUT	I O	7	(TTL Bi-Directional) Internal Master PLL (REF_8K_3). If configuration register bit C_43=0, this pin is a Local 8 KHz Reference 3 Input. External Master PLL (REF_8K_OUT). If configuration register bit C_43=1, this pin is an 8 KHz Reference Output.
REF_8K_2 or CLK_IN	I	6	(TTL Input) Internal Master PLL (REF_8K_2). If configuration register bit C_43=0, this pin is a Local 8 KHz Reference 2 Input. External Master PLL (CLK_IN). If configuration register bit C_43=1, this is a clock input from external master PLL.
REF_8K_1	I	5	(TTL Input) Local 8 KHz Reference 1 Input.
REF_8K_0	I	4	(TTL Input) Local 8 KHz Reference 0 Input.
SI_[3:0]	I	95,94,92,91	(TTL Input, Pull Up) Local Bus Serial Input Data Streams. This pin can be programmed to 2.048, 4.096 or 8.192 Mb/s data rates.
TXD_0	I	9	(TTL Input, Pull Up) Message Channel Transmit Data. This pin is for the SCbus Message channel transmit data input line.
TEST	I	98	(TTL Input) NAND Gate Test Mode Enable. When in test mode (TEST=1) each pin except VDD/VSS/X_OUT is nanded with the preceding pin and output at both DRQ_R and DRQ_T pins.
INT_1	I/O	15	(TTL Bi-directional) Interrupt Request 1. Reserved for future internal HDLC controller. If unused, this pin should be left unconnected.
INT_0	I/O	14	(TTL Bi-directional) Interrupt Request 0. This pin will be asserted (controlled by C_[55:53]) if either SCbus Error, SCbus CLKFAIL, Frame Boundary or Internal Master PLL Error and INT_0 unmasked (C_53 = 1).

## Universal Timeslot Interchange

## SC4000

## Pin Description (continued)

Pin Name	Input/Output	Pin Number	Pin Description
DRO_R or TEST_OUT_0	O	99	(TTL Output) Receive DMA Request. This pin is reserved for a future internal HDLC controller. Otherwise, in Test Mode (TEST=1), this is a NANDed gate test chain 0 output.
DRO_T or TEST_OUT_1	O	100	(TTL Output) Transmit DMA Request. This pin is reserved for a future internal HDLC controller. Otherwise, in Test Mode (TEST=1), this is a NANDed gate test chain 1 output.
SCLKX2N	I/O	46	(SCbus Bi-directional) SCbus System clock x 2.
SCLKX2NA	I/O	47	(SCbus Bi-directional) SCbus Alternate System clock x 2.
SCLK	I/O	49	(SCbus Bi-directional) SCbus System clock. This can be programmed to either 2.048, 4.096 or 8.192 MHz. Set C_0 = 1 to enable the SCLK output driver as master mode. Set C_0 = 0 to disable the SCLK output driver as slave mode.
SCLKA	I/O	50	(SCbus Bi-directional) SCbus Alternate System clock.
SREF_8K	I/O	51	(SCbus Bi-directional) SCbus 8 KHz Reference. If C_46 = 1, the SREF_8K output is enabled at SCbus If C_46 = 0, the SREF_8K output is disabled at SCbus
SREF_8KA	I/O	52	(SCbus Bi-directional) SCbus 8 KHz Alternate Reference.
FSYNCN	I/O	54	(SCbus Bi-directional) SCbus 8 KHz Frame Synchronization signal. Set C_0 = 1 to enable the FSYNCN output driver as master mode. Set C_0 = 0 to disable the FSYNCN output driver as slave mode.
FSYNCNA	I/O	55	(SCbus Bi-directional) SCbus 8 KHz Alternate Frame Synchronization signal.
CLKFAIL	I/O	56	(SCbus Bi-directional) SCbus System Clock Fail signal.
CLKFAILA	I/O	58	(SCbus Bi-directional) SCbus Alternate System Clock Fail signal.
SD_[0:15]	I/O	59,60,62,63, 64,66,67,68, 70,71,72,74, 75,76,77,79	(SCbus Bi-directional) These are SCbus Serial Data Streams can be programmed to 2.048, 4.096 or 8.192 Mb/s data rates.
MC	I/O	80	(SCbus Bi-directional Open Collector) SCbus Message Channel.
MCA	I/O	81	(SCbus Bi-directional Open Collector) SCbus Alternate Message Channel.
L_CLK	I/O	83	(TTL Bi-directional) Local bus Clock Output. It can be programmed to: 2.048, 4.096 or 8.192 MHz if set C_28 = 0. 4.096, 8.192 or 16.384 MHz if set C_28 = 1.
L_FS	I/O	84	(TTL Bi-directional) Local bus 8 KHz Frame Synchronization Output.
SO_[3:0]	I/O	90,88,87,86	(TTL Bi-directional) Local Bus Serial Output Data Streams. It can be programmed to 2.048, 4.096 or 8.192 Mb/s data rates.
MC_CLK	I/O	11	(TTL Bi-directional) Message Channel Data Clock. This pin is a 2.048 MHz output. The clock duty cycle can be programmed by C_14 bit.
RXD	I/O	10	(TTL Bi-directional) Message Channel Receive Data. This pin is for the SCbus message channel receive data output line.
VDD	Power	8,13,29,37,48, 61,65,78,85,89	+5 Volt Power Supply.
VSS	Power	3,18,23,33,41, 45,53,57,69,73, 82,93,97	Ground.

Note: In Test mode (TEST=1), every pin except VDD/VSS/X\_OUT/DRO\_R/DRO\_T is configured as input.

# Universal Timeslot Interchange

# SC4000

### DEVICE OVERVIEW

The SC4000 Universal Timeslot Interchange is designed to provide the hardware interface to the SCbus. Its primary function is exchanging digital data between the Local bus serial port and the SCbus serial port. A microprocessor interface allows the host controller to specify the timeslots and serial lines for this exchange. Both the SCbus and the Local bus can be programmed to operate at either 2.048 Mb/s, 4.096 Mb/s or 8.192 Mb/s.

As shown in Figure 1, the destination routing memory defines the Local Bus to SCbus switch connection. There are 128 destination routing memory locations — one for each Local Bus input channel. The data stored in the destination routing memory selects the timeslot and SCbus serial port connection for the Local Bus input channel. The source routing memory defines the SCbus to Local Bus switch connection. There are 128 source routing memory locations — one for each Local Bus output channel.

The data stored in the source routing memory selects the time slot and SCbus serial port connection for the Local Bus output channel.

### Local Bus Channels to Serial Ports SI and SO Time Slot Assignments

Framing mode	SI_0 and SO_0	SI_1 and SO_1	SI_2 and SO_2	SI_3 and SO_3
2.048 Mb/s	ch[0:31] -> ts[0:31]	ch[32:63] -> ts[0:31]	ch[64:95] -> ts[0:31]	ch[96:127] -> ts[0:31]
4.096 Mb/s	ch[0:63] -> ts[0:63]	ch[64:127] -> ts[0:63]		
8.192 Mb/s	ch[0:127] -> ts[0:127]			

# Universal Timeslot Interchange

# SC4000

Writing to the routing memory is synchronized with SCbus timing. So routing information can be changed only on time slot boundaries. All input data is buffered in holding registers. The entire holding register is transferred to the output registers on a frame boundary basis. All frame-bounded time slots incur a one frame delay as they pass through the switch. Switching data in this fashion supports time slot bundling.

The SO outputs are tri-state controlled on time slot boundaries by the Source Routing Memory Switch Output Enable Bit. This allows SO outputs from multiple devices to be connected to a common line. The data sample position of both the SCbus and the Local bus can be selected for either 50% or 75% of the bit cell.

In addition to switching local bus serial data to and from the SCbus, the SC4000 provides a means of switching parallel data through the microprocessor interface to the SCbus. A frame boundary interrupt helps control the timing of parallel data accesses. Direct reading and writing of parallel access register contents makes for an efficient data transfer. When using direct access, the controlling processor places the address of the target channel on the address bus. In this way, data can be read or written in a single cycle. To avoid data corruption, the application should not access the channel for a time period defined as four clocks before and four clocks after the frame boundary.

The Source Routing Memory Local Connect Enable mode allows the switching of any destination channel to

any source channel without SCbus intervention. This mode accommodates either serial or parallel data transfer. Since data passes through the switch twice in this mode, there is a two-frame delay from input to output.

Diagnostic mode electrically disconnects the SC4000 from the SCbus but allows access through the local bus. This mode is particularly useful for running board diagnostics without upsetting the SCbus. A Master Clock source is required to run this mode.

The SC4000 pinout anticipates a future version of the chip that includes an internal HDLC controller for the message channel. To remain compatible with this and other subsequent versions of the SC4000, applications must write 0 to all "Reserved (read only)" configuration registers.

**Figure 1. Destination and Source Switch Function Block**

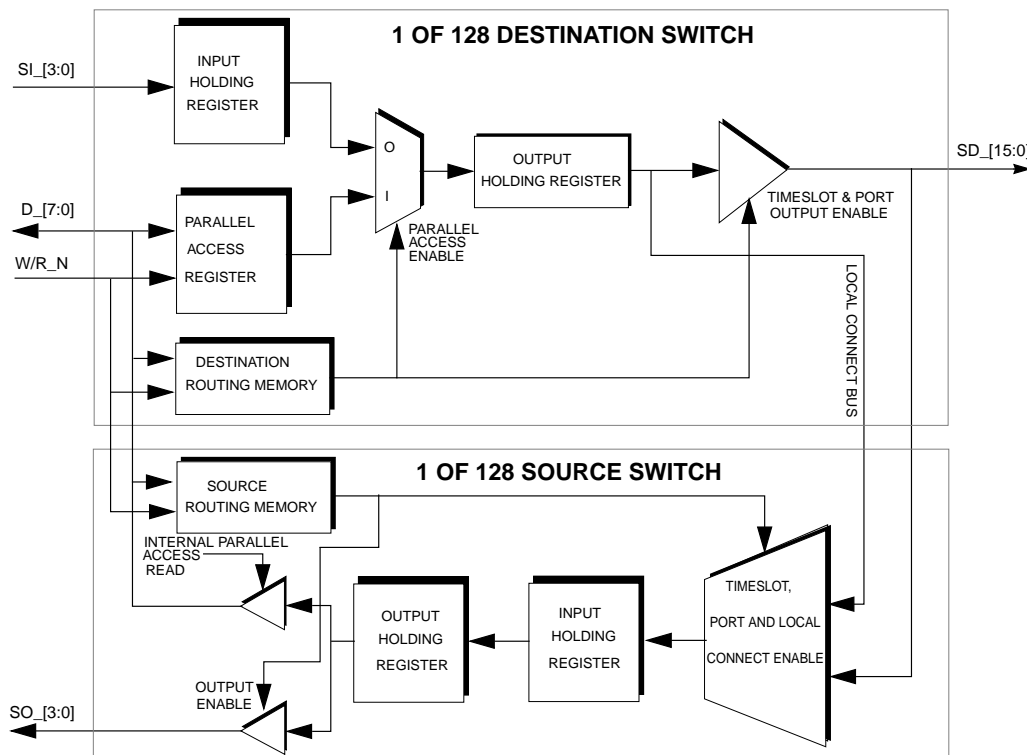

# Universal Timeslot Interchange

# SC4000

## FUNCTION DESCRIPTION

### Switching

The SC4000 allows data switching through the microprocessor interface in any of the following three directions:

- From any local bus serial channel (SI) or parallel data bus D\_[7:0] input to any SCbus channel (SD) output
- From any SCbus channel (SD) input to any output of the local bus serial channel (SO) or parallel data bus D\_[7:0]
- From any of local bus serial channel (SI) or parallel data bus D\_[7:0] input directly through an internal local connect bus to any local bus serial channel (SO) output

As shown in Figure 1, each input SI and output SO channel is mapped to one of

128 unique locations in the destination routing memory and source routing memory, respectively. So data stored in the destination or source routing memory selects the timeslot and serial port of the SCbus. All data is buffered through the input holding register, output holding register or parallel access register for a switching matrix with one frame delay.

### PLL Timing and Clock Control

The SC4000 provides the option of using the internal master PLL (C\_43 = 0) or an external master PLL (C\_43 = 1). As shown in Figure 2, the internal master PLL generates a clock that is frequency-locked to an 8 KHz reference input of either SREF\_8K or REF\_8K[3:0]. When the SC4000 is enabled as SCbus master (C\_0 = 1), a state machine inside the SC4000 uses this clock to generate

SCLK, SCLKX2N and a “free-running” FSYNCN signal based on the speed of the SCbus and the clock frequency. The internal master PLL runs free when:

- Put into free run mode (ignoring reference input changes) by control C\_[42:40]
- The 8 KHz reference input is static “1” or “0”
- The input of X\_IN is less than 65.536 MHz.

The internal master PLL can also generate an interrupt if it cannot lock the selected 8 KHz reference input.

Figure 2. Internal Master PLL (C\_43 = 0) Function Block

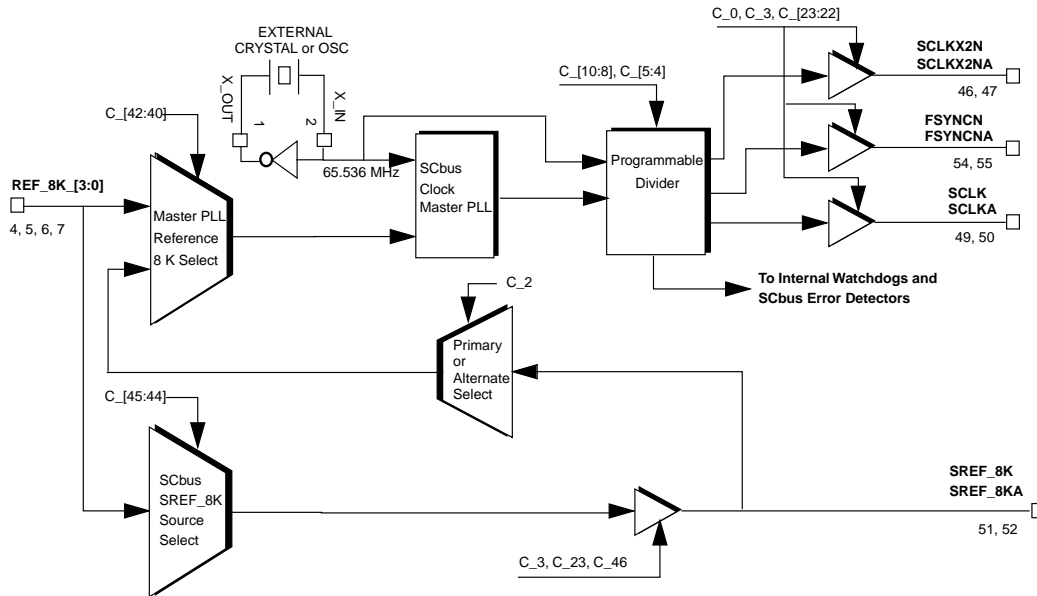

# Universal Timeslot Interchange

# SC4000

Figure 3 shows an external master PLL implementation. The SC4000 provides the 8 KHz reference output signal REF\_8K\_OUT (pin 7) to the external PLL. This 8 KHz reference signal is sourced from either REF\_8K[1:0] or SREF\_8K. The output of the external PLL is then routed back to the SC4000 via CLK\_IN (pin 6). The master clock input (CLK\_IN) frequency select at C\_[10:8] would then be programmed for the external PLL frequency.

As shown in Figure 4, the SC4000 also provides an internal clock PLL and local bus PLL timing control circuitry for both SCbus master and slave operations. The internal clock PLL is used to create the 4.096 or 8.192 MHz timing slaved to the SCbus when the local bus is running faster than the SCbus (i.e., 2.048 MHz at SCbus, 8.096 MHz at local bus). If the SCbus is faster or equal to the local bus,

then the SCbus clocks serve as the internal clock and use to create the local bus clocks as well as message channel clock. The local bus clock PLL is used to create a 2.048 MHz L\_CLK when:

- Local bus framing mode C\_[7:6] is set to 2.048 Mb/s
- A 65.536 MHz clock is supplied on X\_IN
- The C\_29 bit is set to one.

If SCLK stops transitionally such as during a clock fail condition (CLKFAIL = 1), then the local bus clock PLL runs free to generate L\_CLK clock. In addition, the local bus SO lines are tri-stated so that the network interface can continue to run.

### Interrupts Control

The SC4000 can interrupt the host CPU with the interrupt request signal INT\_0

(pin 14). This signal is configured and unmasked by configuration register bits C\_55, C\_54 and C\_53. The interrupt sources are:

- C\_56 SCbus CLKFAIL
- C\_57 Frame Boundary
- C\_58 Internal Master PLL Error
- C\_59 SCbus Error Indicator (logical "OR" of C\_[67:64], C\_[74:72], and C\_[83:80])

The interrupts are structured this way to improve performance by allowing a single read operation (of configuration register byte 7) to determine whether the SC4000 is the source of the interrupt. Each of the SC4000 interrupt sources can be individually masked.

Figure 3. External Master PLL (C\_43 = 1) Function Block

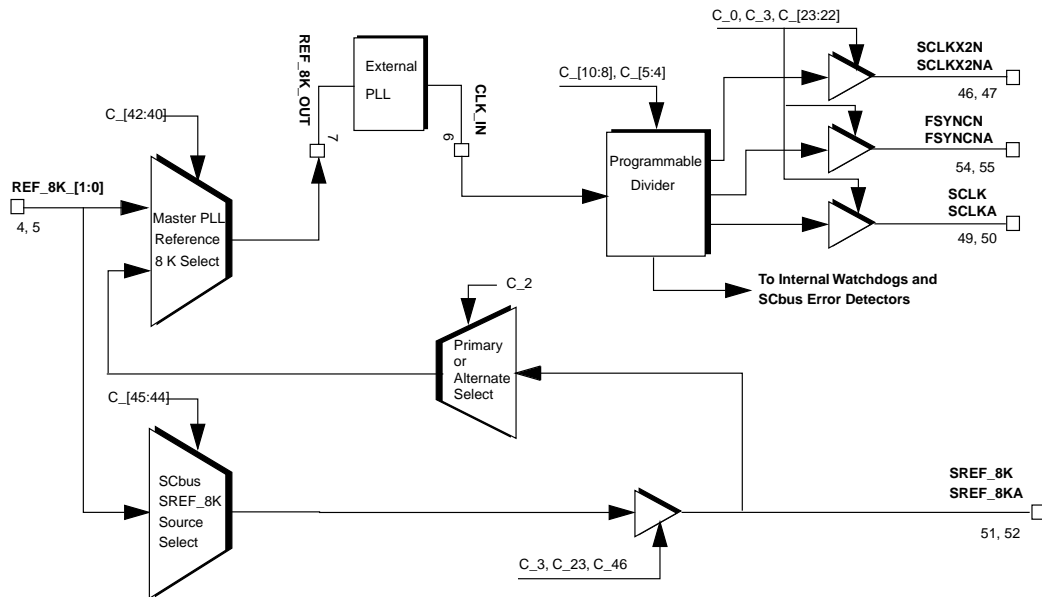

# Universal Timeslot Interchange

# SC4000

Figure 4. Internal PLL and Local Bus PLL Timing Function Block

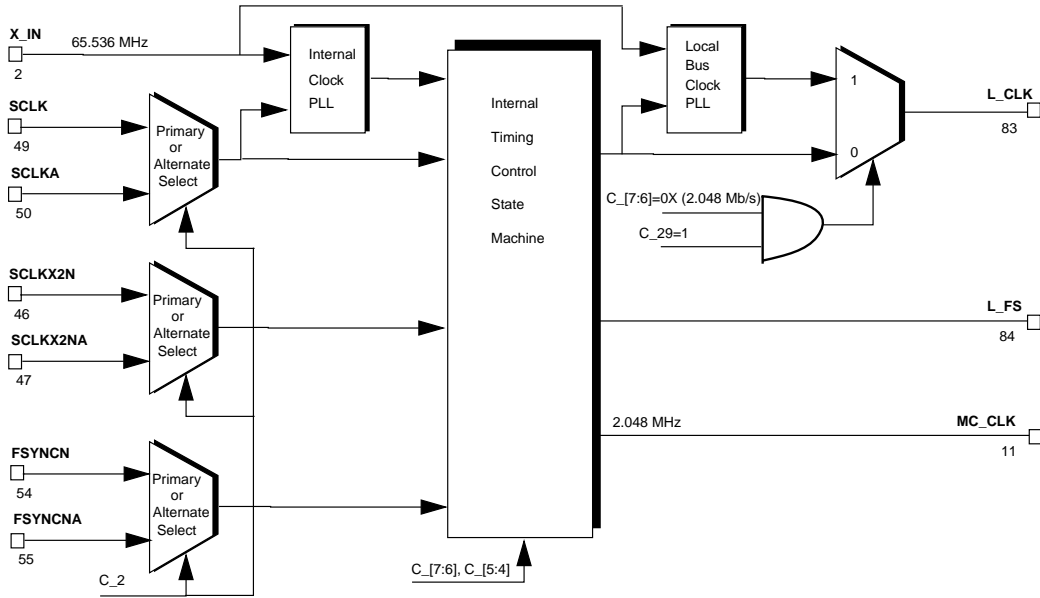



# Universal Timeslot Interchange

# SC4000

### CLKFAIL Timing and Control

When an SC4000 is enabled to be clock master (C\_0 = 1), the chip drives clock and frame sync signals to the SCbus and pulls the CLKFAIL line low. If the SC4000 is then disabled as clock master, the internal state machine waits for the next frame boundary and then stops driving clock and frame sync signals. Instead, it drives the CLKFAIL line high for one clock before tri-stating it (CLK-FAIL is pulled up with 4.7K on every board). An "armed" clock master (C\_1 = 1) contains logic that monitors the CLKFAIL line (C\_51 must be set). If CLKFAIL is sampled high for two consecutive clock periods, then the C\_0 bit is automatically set; the armed master then begins driving clock and frame sync signals and pulls CLKFAIL low. Since the internal state machine was

using the clock and frame sync signals driven by the previous master, the new master takes over without any framing error. It is as if one clock period had been stretched, as shown in Figure 14.

### Message Channel Interface

The SC4000 is designed for use with an HDLC controller to implement the message channel interface. The interface between an HDLC controller and SC4000 consists of the 2.048 MHz MC\_CLK (pin 11), TXD\_0 (pin 9) and RXD (pin 10) lines. Data read from the SCbus MC (pin 80) line is passed straight through the SC4000 to the RXD output. Data read from TXD\_0 can be passed straight through the SC4000 to the MC output, or be buffered internally through a clocked register. Buffering output data is controlled by C\_12. When the Message

Channel is Disabled (C\_15 = 1), TXD\_0 is looped back to the RXD to allow diagnostics to be run on the HDLC controller.

### Operation Mode and Configuration Register Setup

The SC4000 can be configured to function in five different modes shown in the tables below:

- SCbus Clock Slave (Table 1)
- SCbus Clock Master (Table 2)
- SCbus Armed Clock Master (Table 3)
- MVIP Clock Master (Table 4)
- MVIP Clock Slave (Table 5)

Table 6 shows signals that are cross referenced by SCbus and MVIP.

**Table 1. Configuration Register Setup for SCbus Clock Slave**

Operation Mode	Conguration Register Bits Setup	Function Description
SCbus Slave	C_0 = 0	SCbus clock master disabled (Default)
	C_1 = 0	SCbus clock master disarmed (Default)
	C_2	SCbus Primary or Alternate Select 0: Primary SCbus signals selected (Default) 1: Alternate SCbus signals selected
	C_3 = 0	Diagnostic mode disabled (Note)
	C_[5:4]	SCbus Framing mode to select one of the following rate: 0X = 2.048 Mb/s, 256 Bits/Frame, 32 Timeslots/Frame (Default) 10 = 4.096 Mb/s, 512 Bits/Frame, 64 Timeslots/Frame 11 = 8.192 Mb/s, 1024 Bits/Frame, 128 Timeslots/Frame
	C_[7:6]	Local bus Framing mode to select one of the following rate: 0X = 2.048 Mb/s, 256 Bits/Frame, 32 Timeslots/Frame (Default) 10 = 4.096 Mb/s, 512 Bits/Frame, 64 Timeslots/Frame 11 = 8.192 Mb/s, 1024 Bits/Frame, 128 Timeslots/Frame

Note: Default of all configuration register bits except C\_3 are 0

# Universal Timeslot Interchange

# SC4000

**Table 2. Configuration Register Setup for SCbus Clock Master**

Operation Mode	Configuration Register Bits Setup	Function Description
SCbus Master	C_0 = 1	SCbus clock master enabled
	C_1 = 0	SCbus clock master disarmed (Default)
	C_2	SCbus Primary or Alternate Select 0: Primary SCbus signals selected (Default) 1: Alternate SCbus signals selected
	C_3 = 0	Diagnostic mode disabled
	C_[5:4]	SCbus Framing mode to select one of the following rate: 0X = 2.048 Mb/s, 256 Bits/Frame, 32 Timeslots/Frame (Default) 10 = 4.096 Mb/s, 512 Bits/Frame, 64 Timeslots/Frame 11 = 8.192 Mb/s, 1024 Bits/Frame, 128 Timeslots/Frame
	C_[7:6]	Local bus Framing mode to select one of the following rate: 0X = 2.048 Mb/s, 256 Bits/Frame, 32 Timeslots/Frame (Default) 10 = 4.096 Mb/s, 512 Bits/Frame, 64 Timeslots/Frame 11 = 8.192 Mb/s, 1024 Bits/Frame, 128 Timeslots/Frame
	C_[10:8]	Master clock input frequency select: 000 = 2.048 MHz (Default), 001 = 4.096 MHz, 010 = 8.192 MHz, 011 = 16.384 MHz, 100 = 32.768 MHz, 101 = 65.536 MHz, 11X =Reserved
	C_21 = 0	SCbus FSYNCN rate to select one SCLK period (Default)
	C_22	SCbus SCLKX2N and SCLKX2NA output enable control 0: SCbus SCLKX2N and SCLKX2NA output enabled (Default) 1: SCbus SCLKX2N and SCLKX2NA output disabled
	C_23	SCbus Alternate signals output enable control 0: SCbus Alternate signals output disabled (Default) 1: SCbus Alternate signals output enabled
	C_[43:40] (Internal/External Master PLL reference 8K select)	Internal/External Master PLL reference select: If C_43 = 0 select the reference for the internal master PLL from C_[42:40]: 000 = Free-run (Default), 001/010 = Free-run, 011 = SREF_8K/SREF_8KA, 100 = REF_8K_0, 101 = REF_8K_1, 110 = REF_8K_2, 111 = REF_8K_3 (see Figure 2)  If C_43 = 1 select the reference for the external master PLL (output on REF_8K_OUT pin 7) from C_[42:40]: 000 = Free-run (driven high) (Default), 001/010 = Free-run (driven high), 011 = SREF_8K/SREF_8KA, 100 = REF_8K_0, 101 = REF_8K_1, 110/111 = Tri-state (Z) (see Figure 3)
	C_51 = 1	SCbus CLKFAIL latch debounce enabled

## Universal Timeslot Interchange

## SC4000

**Table 3. Configuration Register Setup for SCbus Armed Clock Master**

Operation Mode	Configuration Register Bits Setup	Function Description
SCbus Armed Master	C_0 = 0	SCbus clock master disabled initially
	C_1 = 1	SCbus clock master armed. When CLKFAIL goes high, C_0 bit will be automatically set and SC4000 becomes clock master
	C_2	SCbus Primary or Alternate Select 0: Primary SCbus signals selected (Default) 1: Alternate SCbus signals selected
	C_3 = 0	Diagnostic mode disabled
	C_[5:4]	SCbus Framing mode to select one of the following rate: 0X = 2.048 Mb/s, 256 Bits/Frame, 32 Timeslots/Frame (Default) 10 = 4.096 Mb/s, 512 Bits/Frame, 64 Timeslots/Frame 11 = 8.192 Mb/s, 1024 Bits/Frame, 128 Timeslots/Frame
	C_[7:6]	Local bus Framing mode to select one of the following rate: 0X = 2.048 Mb/s, 256 Bits/Frame, 32 Timeslots/Frame (Default) 10 = 4.096 Mb/s, 512 Bits/Frame, 64 Timeslots/Frame 11 = 8.192 Mb/s, 1024 Bits/Frame, 128 Timeslots/Frame
	C_[10:8]	Master clock input frequency select: 000 = 2.048 MHz (Default), 001 = 4.096 MHz, 010 = 8.192 MHz, 011 = 16.384 MHz, 100 = 32.768 MHz, 101 = 65.536 MHz, 11X = Reserved
	C_21 = 0	SCbus FSYNCN rate to select one SCLK period (Default)
	C_22	SCbus SCLKX2N and SCLKX2NA output enable control 0: SCbus SCLKX2N and SCLKX2NA output enabled (Default) 1: SCbus SCLKX2N and SCLKX2NA output disabled
	C_23	SCbus Alternate signals output enable control 0: SCbus Alternate signals output disabled (Default) 1: SCbus Alternate signals output enabled
	C_[43:40] (Internal/External Master PLL reference 8K select)	Internal/External Master PLL reference select: If C_43 = 0 select the reference for the internal master PLL from C_[42:40]: 000 = Free-run (Default), 001/010 = Free-run, 011 = SREF_8K/SREF_8KA, 100 = REF_8K_0, 101 = REF_8K_1, 110 = REF_8K_2, 111 = REF_8K_3 (see Figure 2)  If C_43 = 1 select the reference for the external master PLL (output on REF_8K_OUT pin 7) from C_[42:40]: 000 = Free-run (driven high) (Default), 001/010 = Free-run (driven high), 011 = SREF_8K/SREF_8KA, 100 = REF_8K_0, 101 = REF_8K_1, 110/111 = Tri-state (Z) (see Figure 3)
C_51 = 1	SCbus CLKFAIL latch debounce enabled	

# Universal Timeslot Interchange

# SC4000

**Table 4. Configuration Register Setup for MVIP Clock Master**

Operation Mode	Configuration Register Bits Setup	Function Description
MVIP Master	C_0 = 1	MVIP clock master enabled
	C_1 = 0	MVIP clock master disarmed (Default)
	C_2 = 0	Primary SCbus signals selected (Default)
	C_3 = 0	Diagnostic mode disabled (Note 1)
	C_[5:4] = 00	MVIP Framing mode to select only one rate: 0X = 2.048 Mb/s, 256 Bits/Frame, 32 Timeslots/Frame (Default)
	C_[7:6]	Local bus Framing mode to select one of the following rate: 0X = 2.048 Mb/s, 256 Bits/Frame, 32 Timeslots/Frame (Default) 10 = 4.096 Mb/s, 512 Bits/Frame, 64 Timeslots/Frame 11 = 8.192 Mb/s, 1024 Bits/Frame, 128 Timeslots/Frame
	C_[10:8]	Master clock input frequency select: 000 = 2.048 MHz (Default), 001 = 4.096 MHz, 010 = 8.192 MHz, 011 = 16.384 MHz, 100 = 32.768 MHz, 101 = 65.536 MHz, 11X = Reserved
	C_21 = 1	MVIP F0/ rate to select one C4/ period
	C_22 = 0	MVIP C4/ output enabled (Default)
	C_23 = 0	SCbus Alternate signals output disabled (Default)
	C_[43:40] (Internal/External Master PLL reference 8K select)	Internal/External Master PLL reference select: If C_43 = 0 select the reference for the internal master PLL from C_[42:40]: 000 = Free-run (Default), 001/010 = Free-run, 011 = SEC_8K, 100 = REF_8K_0, 101 = REF_8K_1, 110 = REF_8K_2, 111 = REF_8K_3 (see Figure 2)  If C_43 = 1 select the reference for the external master PLL (output on REF_8K_OUT pin 7) from C_[42:40]: 000 = Free-run (driven high) (Default), 001/010 = Free-run (driven high), 011 = SEC_8K, 100 = REF_8K_0, 101 = REF_8K_1, 110/111 = Tri-state (Z) (see Figure 3)

**Table 5. Configuration Register Setup for MVIP Clock Slave**

Operation Mode	Configuration Register Bits Setup	Function Description
MVIP Slave	C_0 = 0	MVIP clock master disabled (Default)
	C_1 = 0	MVIP clock master disarmed (Default)
	C_2 = 0	Primary SCbus signals selected (Default)
	C_3 = 0	Diagnostic mode disabled
	C_[5:4] = 00	MVIP Framing mode to select only one rate: 0X = 2.048 Mb/s, 256 Bits/Frame, 32 Timeslots/Frame (Default)
	C_[7:6]	Local bus Framing mode to select one of the following rate: 0X = 2.048 Mb/s, 256 Bits/Frame, 32 Timeslots/Frame (Default) 10 = 4.096 Mb/s, 512 Bits/Frame, 64 Timeslots/Frame 11 = 8.192 Mb/s, 1024 Bits/Frame, 128 Timeslots/Frame

## Universal Timeslot Interchange

## SC4000

Table 6. SCbus/MVIP Signals Cross Reference

SCbus 26-Pin Connector	SCbus Signal	MVIP Signal	MVIP 40-Pin Connector
1	SCLKX2N	C4/	31
2	GND	GND	30, 32
3	SCLK	C2	35
4	SREF_8K	SEC_8K	37
5	FSYNCN	F0/	33
6	CLKFAIL	N/A	N/A
7	SD_0	DSi0	8
8	GND	GND	34
9	SD_1	DSo0	7
10	SD_2	DSi1	10
11	SD_3	DSo1	9
12	SD_4	DSi2	12
13	SD_5	DSo2	11
14	SD_6	DSi3	14
15	GND	GND	36
16	SD_7	DSo3	13
17	SD_8	DSi4	16
18	SD_9	DSo4	15
19	SD_10	DSi5	18
20	SD_11	DSo5	17
21	GND	GND	38
22	SD_12	DSi6	20
23	SD_13	DSo6	19
24	SD_14	DSi7	22
25	SD_15	DSo7	21
26	MC	N/A	N/A

# Universal Timeslot Interchange

# SC4000

### Register Access Schemes

The SC4000 features two address access schemes. One is an indirect access scheme (C\_11 = 0) to reduce the number of pins required for the microprocessor

address bus interface from nine to two (A\_[1:0]), as shown in Figure 5. The other is a combination of both indirect and direct parallel access schemes (C\_11 = 1). Using the combination requires

that all nine microprocessor address pins (A\_[8:0]) be used, as shown in Figure 6.

**Figure 5. Using Two Pins A\_[1:0] for Address Bus Interface Scheme (C\_11 = 0)**

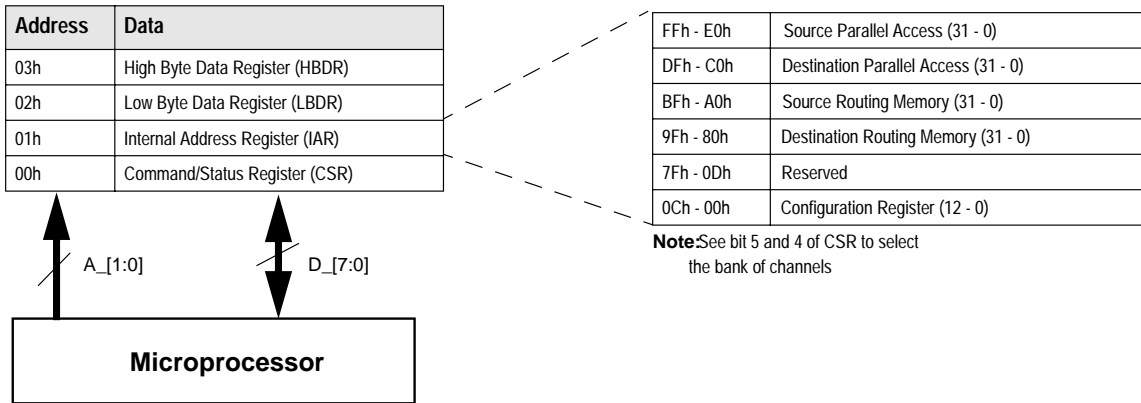

**Figure 6. Using Nine Pins A\_[8:0] for Address Bus Interface Scheme (C\_11 = 1)**

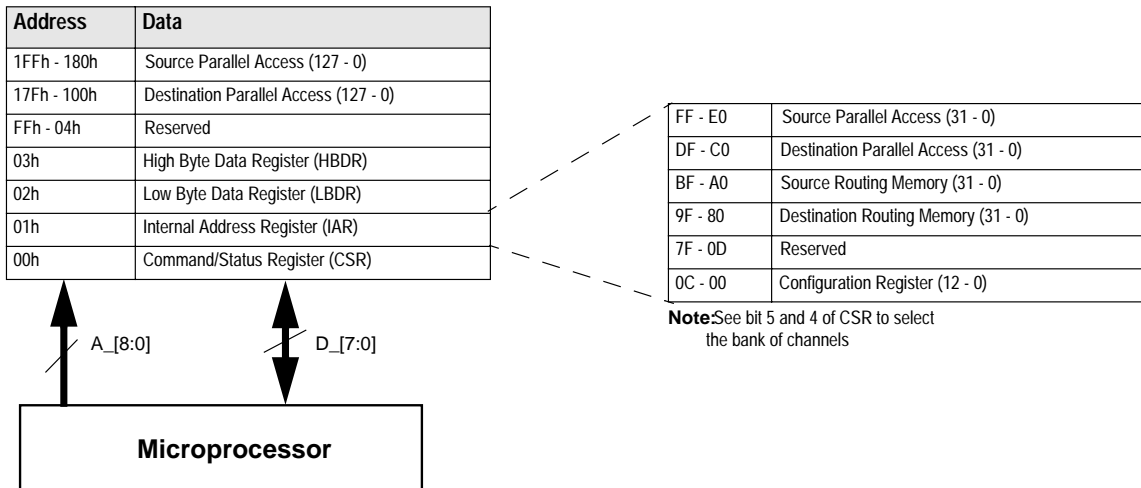

## Universal Timeslot Interchange

## SC4000

## MICROPROCESSOR INTERFACE

## I/O Address Map

With Direct R/W to Parallel Access  
Registers Disabled (C\_11=0) (default)

A_[1:0]	REGISTER
3h	High Byte Data Register (HBDR)
2h	Low Byte Data Register (LBDR)
1h	Internal Address Register (IAR)
0h	Command / Status Register

With direct R/W to Parallel Access  
Register Enable (C\_11=1)

A_[8:0]	REGISTER
1FFh:180h	Source Parallel Access Register Ch. 127:0
17Fh:100h	Destination Parallel Access Register Ch. 127:0
0FFh:004h	Reserved
003h	High Byte Data Register (HBDR)
002h	Low Byte Data Register (LBDR)
001h	Internal Address Register (IAR)
000h	Command / Status Register

## Command / Status Register (Address = 0h)

D_[7:0]	Definition
0	Busy (Read only)
1	Read Command (Write only)
2	Write Command (Write only)
3	Terminate Command (Read/Write)
[5:4]	Channel Bank Select Register [1:0] (Read/Write)
6	Channel Bank Select Register Enable (Write only)
7	Reset (Read/Write)

**Note:** Setting more than one command (Read, Write, Terminate or Reset) during an access to the Command/Status register is not recommended.

## Busy (D\_0) (Read Only)

This bit is set ("1") when a command that requires synchronization with the SC4000's internal state machine has been initiated. This bit clears ("0") when the command is completed.

The following commands require synchronization:

- Destination Routing Memory Write command
- Source Routing Memory Write command
- Indirect Parallel Access Destination Write command
- Indirect Parallel Access Source Read command

## Read (D\_1) (Write only)

Setting this bit ("1") initiates a read of the register pointed to by the Internal Address Register. When the Busy bit is clear ("0"), the contents of the register to be read are available by reading the Low byte & HighByte Data register. It is not necessary to clear ("0") this bit after it has been set ("1").

**Note:** Set this bit for an Indirect Parallel Access Source Read (this is the only "READ" requiring synchronization).

For reads which do not require synchronization, the data registers can be read immediately after writing the internal address register.

## Write (D\_2) (Write only)

Setting this bit ("1") initiates a write to the register selected by the Internal Address Register. When the Busy bit is clear ("0"), the contents of the target register have been updated using the data stored in the Low Byte & High Byte Data Register. It is not necessary to clear ("0") this bit after it has been set ("1").

## Terminate (D\_3) (Read/Write)

Setting this bit ("1") terminates a command that requires synchronization with the SC4000's internal state machine. This is necessary to complete a command when the SC4000's internal

state machine has stopped running (no SCLK). The command in process is completed asynchronously and the Busy bit is cleared. It is necessary to clear ("0") this bit after it has been set ("1").

**Note:** A new command (Read or Write) should not be issued until after the Terminate bit is cleared ("0").

## Channel Bank Select Register

## [1:0] (D\_[5:4]) (Read/Write)

This field determines the bank of channels that a command will affect. The Channel Bank Select Register field is combined with the Internal Address Register to provide access to the channel specific registers (routing and parallel access). D\_[5:4] selects the bank of channels to be accessed. This field is cleared ("00") on reset.

D\_[5:4] = 00 -> Ch. 0 - 31

D\_[5:4] = 01 -> Ch.32 - 63

D\_[5:4] = 10 -> Ch.64 - 95

D\_[5:4] = 11 -> Ch.96 - 127

## Channel Bank Select Register Enable (D\_6) (Write only)

Writing to the command register with this bit set ("1") enables the Channel bank select field to be changed. Writing to the command register with this bit cleared ("0") causes the Channel Bank Select Register field to retain its previous value.

**Note 1:** The Channel Bank Select Register may be changed during a write cycle which also initiates a Read or Write command. The Read or Write command affects the register pointed to by the new value written into the Channel Bank Select Register.

**Note 2:** The Channel Bank Select Register should not be changed if the microprocessor interface is busy.

**Note 3:** The Channel Bank Select Register should not be changed during a write cycle that either sets (0->1) or clears (1->0) the Terminate command.

# Universal Timeslot Interchange

# SC4000

### Reset (D\_7) (Read/Write)

Setting this bit ("1") puts the SC4000 in reset and initializes the Configuration, Routing and Parallel Access Registers. This command is analogous to the function of the RESET pin. Clearing this bit ("0") returns the SC4000 to normal operation, ready for configuration.

### Internal Address Register (Address = 01h)

D_[7:0]	Definition
7:0	Internal Address Register (IAR_[7:0])

### Internal Address Register Map

IAR_[7:0]	Register	IAR_[7:0]	Register
FFh:80h	Channel Specific Registers	FFh:E0h	Source Parallel Access
		DFh:C0h	Destination Parallel Access
		BFh:A0h	Source Routing Memory
		9Fh:80h	Destination Routing Memory
7Fh:0Dh	Reserved		
0Ch:00h	Configuration Registers		

### Low Byte Data Register (Address = 02h)

D_[7:0]	Definition
7:0	Low byte Data Register (LBDR_[7:0])

### High Byte Data Register (Address = 03h)

D_[7:0]	Definition
7:0	High byte Data Register (HBDR_[7:0])



# Universal Timeslot Interchange

# SC4000

### Channel Specific Registers

The Channel Specific Registers are divided into four groups. A group is selected by bits 5 through 7 of the internal address register.

- IAR\_[7:5]  
100 -> Destination Routing Memory
- 101 -> Source Routing Memory
- 110 -> Destination Parallel Access
- 111 -> Source Parallel Access

Channels within these groups are selected by bits 4 through 0 (IAR\_[4:0]) of the Internal Address Register and bits 1 and 0 (D\_[5:4] Command/Status Register) of the Channel Bank Select Register (CBSR)

### Channel Specific Registers Map

IAR[7:0]		D_[5:4] of Command/Status Register (D_6 = 1)			
		CBSR_[1:0] = 00	CBSR_[1:0] = 01	CBSR_[1:0] = 10	CBSR_[1:0] = 11
IAR_[7:5] FFh - E0h  Source Parallel Access	IAR_[4:0] = 1Fh	Ch. 31	Ch. 63	Ch. 95	Ch. 127
	IAR_[4:0] = 1Eh	Ch. 30	Ch. 62	Ch. 94	Ch. 126
	.	.	.	.	.
	.	.	.	.	.
	IAR_[4:0] = 01h	Ch. 1	Ch. 33	Ch. 65	Ch. 97
IAR_[4:0] = 00h	Ch. 0	Ch. 32	Ch. 64	Ch. 96	
IAR_[7:5] DFh - C0h  Destination Parallel Access	IAR_[4:0] = 1Fh	Ch. 31	Ch. 63	Ch. 95	Ch. 127
	IAR_[4:0] = 1Eh	Ch. 30	Ch. 62	Ch. 94	Ch. 126
	.	.	.	.	.
	.	.	.	.	.
	IAR_[4:0] = 01h	Ch. 1	Ch. 33	Ch. 65	Ch. 97
IAR_[4:0] = 00h	Ch. 0	Ch. 32	Ch. 64	Ch. 96	
IAR_[7:5] BFh - A0h  Source Routing Memory	IAR_[4:0] = 1Fh	Ch. 31	Ch. 63	Ch. 95	Ch. 127
	IAR_[4:0] = 1Eh	Ch. 30	Ch. 62	Ch. 94	Ch. 126
	.	.	.	.	.
	.	.	.	.	.
	IAR_[4:0] = 01h	Ch. 1	Ch. 33	Ch. 65	Ch. 97
IAR_[4:0] = 00h	Ch. 0	Ch. 32	Ch. 64	Ch. 96	
IAR_[7:5] 9Fh - 80h  Destination Routing Memory	IAR_[4:0] = 1Fh	Ch. 31	Ch. 63	Ch. 95	Ch. 127
	IAR_[4:0] = 1Eh	Ch. 30	Ch. 62	Ch. 94	Ch. 126
	.	.	.	.	.
	.	.	.	.	.
	IAR_[4:0] = 01h	Ch. 1	Ch. 33	Ch. 65	Ch. 97
IAR_[4:0] = 00h	Ch. 0	Ch. 32	Ch. 64	Ch. 96	

# Universal Timeslot Interchange

# SC4000

### Destination Routing Memory—Low Byte

LBDR_[7:0]	Definition
[6:0]	Time-slot Select [6:0]
7	Reserved

#### Time-Slot Select [6:0] (Read/write)

This field selects the SCbus Time-Slot that a Destination Channel is routed to.

- 00h -> SCbus Time-Slot 0 (Default)
- 01h -> SCbus Time-Slot 1
- 02h -> SCbus Time-Slot 2
- .
- .
- 7Eh -> SCbus Time-Slot 126
- 7Fh -> SCbus Time-Slot 127

### Destination Routing Memory— High Byte

HBDR_[7:0]	Definition
[3:0]	Port Select [3:0]
[5:4]	Reserved
6	Parallel Access Enable
7	Switch Output Enable

#### Port Select [3:0] (Read/Write)

This field selects the SCbus Port that a Destination Channel is routed to.

- 0h -> SCbus SD\_0 (Default)
- 1h -> SCbus SD\_1
- 2h -> SCbus SD\_2
- .
- .
- Eh -> SCbus SD\_14
- Fh -> SCbus SD\_15

#### Parallel Access Enable (Read/Write)

This bit enables the Destination Parallel Access channel to be output in place of the SI Local Bus serial stream.

- 0 -> Parallel Access Disabled (Default)
- 1 -> Parallel Access Enabled

#### Switch Output Enable (Read/Write)

This bit enables the Switch Output to the SCbus.

0 -> Output Disabled (Default)

1 -> Output Enabled

### Source Routing Memory— Low Byte

LBDR_[7:0]	Definition
[6:0]	Time-Slot/Channel Select [6:0]
7	Reserved

#### Time-Slot/Channel Select [6:0] (Read/Write)

If Local Connect is disabled (default) this field selects the SCbus Time-Slot that is routed to a Source Channel.

- 00h -> SCbus Time-Slot 0 (Default)
- 01h -> SCbus Time-Slot 1
- 02h -> SCbus Time-Slot 2
- .
- .
- 7Eh -> SCbus Time-Slot 126
- 7Fh -> SCbus Time-Slot 127

If Local Connect is enabled this field selects the Destination Channel that is routed to a Source Channel.

- 00h -> Destination Channel 0 (Default)
- 01h -> Destination Channel 1
- 02h -> Destination Channel 2
- .
- .
- 7Eh -> Destination Channel 126
- 7Fh -> Destination Channel 127

### Source Routing Memory—High byte

HDBR_[7:0]	Definition
[3:0]	Port Select [3:0]
[5:4]	Reserved
6	Local Connect Enable
7	Switch Output Enable

#### Port Select [3:0] (Read/Write)

This field selects the SCbus Port that is routed to a Source Channel.

- 0h -> SCbus SD\_0 (Default)
- 1h -> SCbus SD\_1

2h -> SCbus SD\_2

- .
- .
- Eh -> SCbus SD\_14
- Fh -> SCbus SD\_15

If Local Connect is enabled this field is don't care.

#### Local Connect Enable (Read/Write)

This bit enables the Local Connection of a Destination Channel to a Source Channel.

- 0 -> Local Connect Disabled (Default)
- 1 -> Local Connect Enabled

#### Switch Output Enable (Read/Write)

This bit enables the Switch Output to the Local Bus.

- 0 -> Output Disabled (Default)
- 1 -> Output Enabled

#### Parallel Access

The parallel access channels can be accessed two ways: Indirect and Direct.

#### Destination Parallel Access

LBDR_[7:0]	Definition
[7:0]	Serial Data Bit [1:8]

#### Serial Data [1:8] (Read/Write)

This register contains the byte to be transmitted when Destination Routing Memory Parallel Access is enabled

**Note:** When converted from parallel to serial, bit 1 is transmitted first.

**Note** This register is cleared ("00") on Reset.

#### Source Parallel Access

LBDR_[7:0]	Definition
[7:0]	Serial Data Bit [1:8]

#### Serial Data [1:8] (Read Only)

This register contains the byte received from the Source Channel selected by the Source Routing Memory.

**Note:** When converted from serial to parallel, bit 1 is received first.

## Universal Timeslot Interchange

## SC4000

## CONFIGURATION REGISTERS

## Configuration Register Byte 0, IAR = 00H

LBDR_[7:0]	C_[7:0]	Definition
0	0	SCbus Clock Master
1	1	SCbus Clock Master Arm
2	2	SCbus Primary/Alternate Select
3	3	Diagnostic Mode Enable
[5:4]	[5:4]	SCbus Framing Mode [1:0]
[7:6]	[7:6]	Local Bus Framing Mode [1:0]

**SCbus Clock Master (C\_0) (Read/Write)**

This bit is synchronized with the Master Clock Input enables the SC4000 to start and stop being SCbus Clock Master.

0-> SCbus Clock Master Disabled (Default)

1-> SCbus Clock Master Enabled

**Note:** With IAR=00H and LBDR D\_0=0 issue Terminate command to asynchronously stop being SCbus Clock Master when no Master Clock Input is present (i.e dead clock)

**SCbus Clock Master Arm (C\_1) (Read/Write)**

The process of becoming SCbus Clock Master can be sped up by arming the SC4000 which is intended to become clock master in the event of a clock failure. When a SC4000 is armed and CLKFAIL=1 the C\_0 bit is automatically set. The SC4000 begins driving the SCbus within 4 clocks of CLKFAIL going high.

0-> SCbus Clock Master Disarmed (Default)

1-> SCbus Clock Master Armed

**Note:** C\_51 SCbus CLKFAIL Debounce Enable must be set to use this feature.

**SCbus Primary/Alternate Select (C\_2) (Read/Write)**

The SC4000 provides Alternate SCbus signals for fault tolerance. This bit controls internal signal selection.

0->Primary SCbus signals selected (Default)

1->Alternate SCbus Signals selected

**Diagnostic Mode Enable (C\_3) (Read/Write)**

In Diagnostic Mode the SC4000's SCbus output drivers and receivers are electrically disconnected from the SCbus. Internally, the SCbus outputs are looped back to their corresponding inputs. This creates a virtual SCbus within the SC4000 that can be used to test thoroughly the SC4000 without disrupting normal SCbus traffic.

0->Diagnostic Mode Disabled

1->Diagnostic Mode Enabled (default)

**Note 1:** Diagnostic Mode is Enabled when the SC4000 is reset.

**Note 2:** A clock must be present at the Master Clock input to use this mode.

**SCbus Framing Mode [1:0](C\_[5:4]) (Read/Write)**

0x -> 2.048 Mb/s, 256 Bits/Frame, 32 Timeslots/Frame (Default)

10 -> 4.096 Mb/s, 512 Bits/Frame, 64 Timeslots/frame

11 -> 8.192 Mb/s, 1024 Bits/Frame, 128 Timeslots/Frame

**Local bus Framing Mode [1:0](C\_[7:6]) (Read/Write)**

0x -> 2.048 Mb/s, 256 Bits/Frame, 32 Timeslots/Frame (Default)

10 -> 4.096 Mb/s, 512 Bits/Frame, 64 Timeslots/frame

11 -> 8.192 Mb/s, 1024 Bits/Frame, 128 Timeslots/Frame

**Note:** If the Local Bus framing mode selection is for a higher data rate than that of the SCbus framing mode, then a 65.536 MHz clock must be provided on X\_IN.

## Configuration Register Byte 1, IAR = 01H

LBDR_[7:0]	C_[15:8]	Definition
[2:0]	[10:8]	Master Clock Input Frequency Select [2:0]
3	11	Direct R/W to Parallel Access Registers Enable
4	12	Message Channel Registered TXD Enable
5	13	Message Channel TXD_0 or TXD_1 (internal HDLC) Select
6	14	Message Channel Clock Duty Cycle Select
7	15	Message Channel Output Disable (w/Loopback)

**Master Clock Input Frequency Select [2:0] (C\_[10:8]) (Read/Write)**

000-> 2.048 MHz (Default)

001-> 4.096 MHz

010-> 8.192 MHz

011->16.384 MHz

100-> 32.768 MHz

101-> 65.536 MHz

110-> Reserved

111-> Reserved

**Note:** The Master Clock Input may be sourced from either X\_IN or CLK\_IN (see C\_43).

**Direct R/W to Parallel Access Registers Enable (C\_11) (Read/Write)**

0-> Direct R/W Disabled (Default)

1-> Direct R/W Enabled

**Note:** When Disabled A\_[8:2] is don't care. When Enabled address setup to falling edge of WR\_N or STRB\_N is required.

**Message Channel Registered TXD Enable (C\_12) (Read/Write)**

0-> TXD Passed Through onto MC (Default)

1-> TXD Registered onto MC

# Universal Timeslot Interchange

# SC4000

**Note:**When C\_12=0 the HDLC Controller must be programmed to output TXD on the Rising edge of MC\_CLK. When C\_12=1 the HDLC controller must be programmed to output TXD on the falling edge of MC\_CLK.

**Message Channel TXD\_0 or TXD\_1 Select (C\_13) (Read/Write)**

0-> TXD\_0 External HDLC Controller (Default)

1-> TXD\_1 Future Internal HDLC Controller

**Note:**If TXD\_1 is selected on an SC4000 without an Internal HDLC Controller all 1's will be output on MC (idle).

**Message Channel Clock Duty Cycle Select (C\_14) (Read/Write)**

0-> 50% (Default)

1-> 75% (2 & 4 Mb/s SCbus modes), 62.5% (8 Mb/s SCbus)

**Note:** SCLKX2N must be present to select 75% when SCbus is 2 Mb/s.

**Message Channel Output Disable (W/ loopback) (C\_15) (Read/Write)**

0-> Message Channel Output Enabled (Default)

1-> Message Channel Output Disabled

**Note:**When the Message Channel is Disabled, TXD is looped back to the RXD to allow diagnostics runs on the HDLC Controller.

**Configuration Register Byte 2, IAR = 02H**

LBDR_[7:0]	C_[23:16]	Definition
0	16	SCbus SD Sample Position
1	17	Local bus SI Sample Position
2	18	SCbus SD Output Delay Enable
3	19	Local bus SO Output Delay Enable
4	20	SCbus FSYNCN Sample position
5	21	SCbus FSYNCN Rate
6	22	SCbus SCLKX2N, SCLKX2NA Output Disable
7	23	SCbus Alternate (A) Signals Output Enable

**SCbus SD Sample Position (C\_16) (Read/Write)**

0-> Sample at 50% of Bit Cell (Default)

1-> Sample at 75% of Bit Cell

**Note:** SCLKX2N must be present to select 75% sample.

**Local Bus SI Sample Position (C\_17) (Read/Write)**

0-> Sample at 50% of Bit Cell (Default)

1-> Sample at 75% of Bit Cell

**Note 1:**To select 75% sample, SCLKX2N must be present or the local bus framing mode must be set to a data rate that is either higher or lower than the SCbus framing mode.

**Note 2:**To select 75% sample (C\_17=1), it is not necessary to select the L\_CLK rate equal to 2X (C\_28=1)

**SCbus SD Output Delay Enable (C\_18) (Read/Write)**

To avoid bus contention, enabled SCbus SD outputs are delayed when coming out of tri-state.

0-> SCbus SD Output Delay Disabled (Default)

1-> SCbus SD Output Delay Enabled

**Local bus SO Output Delay Enable (C\_19) (Read/Write)**

To avoid bus contention, enabled local bus SO outputs are delayed when coming out of tri-state.

0-> Local bus SO Output Delay Disabled (Default)

1-> Local bus SO Output Delay Enabled

**SCbus FSYNCN Sample Position (C\_20) (Read/Write)**

0-> Sample at rising edge of SCLK (Default)

1-> Sample at rising edge of SCLKX2N with SCLK high.

**SCbus FSYNCN Rate (C\_21) (Read/Write)**

This bit determines the clock by which the FSYNCN signal is generated.

0 -> 1 SCLK period (Default)

1 -> 1 SCLKX2N period

**Note:** This mode is provided for MVIP compatibility.

**SCbus SCLKX2N, SCLKX2NA Output Disable(C\_22) (Read/Write)**

This bit disables the SCLKX2N and SCLKX2NA outputs when they are not required. When disabled, the outputs are tri-stated.

0-> SCLKX2N and SCLKX2NA Outputs Enabled (Default)

1-> SCLKX2N and SCLKX2NA Outputs Disabled

## Universal Timeslot Interchange

## SC4000

**SCbus Alternate (A) Signals Output Enable (C\_23) (Read/Write)**

This bit enables the SCbus Alternate ("A") Signals Output (when required). When disabled, the outputs are tri-stated.

0-> SCbus Alternate ("A") Signals Output Disabled (Default)

1-> SCbus Alternate ("A") Signals Output Enabled

**Configuration Register Byte 3, IAR = 03H**

LBDR_[7:0]	C_[31:24]	Definition
0	24	Local bus L_CLK Polarity
1	25	Local bus L_FS Polarity
[3:2]	[27:26]	Local bus L_FS Position [1:0]
4	28	Local bus L_CLK and L_FS Rate
5	29	Local bus L_CLK DPLL Enable
6	30	Local bus L_CLK 8.192 MHz 62.5% duty cycle Enable
7	31	Reserved (0) (Read only)

**Local bus L\_CLK Polarity (C\_24) (Read/Write)**

0-> L\_CLK Non-Inverted (Default)

1-> L\_CLK Inverted

**Local bus L\_FS Polarity (C\_25) (Read/Write)**

0-> L\_FS Non-Inverted (Default)

1-> L\_FS Inverted

**Local bus L\_FS Position (C\_[27:26]) (Read/Write)**

00-> L\_FS occurs during the last clock period of the frame (Default)

01-> L\_FS straddles the frame boundary

10-> L\_FS occurs during the first clock period of the frame

11-> Reserved

**Local bus L\_CLK & L\_FS Rate (C\_28) (Read/Write)**

0-> L\_CLK & L\_FS equal to the Local bus data rate (Default)

1-> L\_CLK & L\_FS equal to 2 times the Local bus data rate

**Note:** To select the 2x rate, SCLKX2N must be present or the Local bus framing mode must be set to a data rate that is either higher or lower than the SCbus framing mode.

**Local bus L\_CLK DPLL Enable (C\_29) (Read/Write)**

This mode is provided to maintain a continuous L\_CLK for network interfaces during a Clock Fail condition.

0->L\_CLK DPLL Disabled (Default)

1->L\_CLK DPLL Enabled

**Note 1:** The Local bus Framing Mode (C\_[7:6]) must be set to 2.048 Mb/s and a 65.536MHz Clock must be supplied on X\_IN.

**Note 2:** When Enabled L\_CLK will run free during an SCbus Clock Fail condition.

**Note 3:** When the DPLL enters the free-run, the Local bus SO lines are tri-stated.

**Local bus L\_CLK 8.192 MHz 62.5% Duty Cycle (C\_30) (Read/Write)**

0-> L\_CLK 8.192 MHz 62.5% Duty Cycle Disabled (Default)

1-> L\_CLK 8.192 MHz 62.5% Duty Cycle Enabled

**Note:** To enable L\_CLK 8.192 MHz 62.5% Duty Cycle, the Local bus Framing Mode (C\_[7:6]) must be set to 8.192 Mb/s and the SCbus Framing Mode (C\_[5:4]) must be set to 4.096 Mb/s or 2.048 Mb/s. C\_28 must be set to 0.

**Configuration Register Byte 4, IAR = 04H**

LBDR_[7:0]	C_[39:32]	Definition
[3:0]	[35:32]	Revision field (read only)
[7:4]	[39:36]	Version field (SC4000 = 1H, SC2000 = 0H) (Read only)

**Version/Revision Status (C\_[39:32])**

The Version/Revision Register is a read only register. It is intended for use to identify SCxxxx devices.

This field may be changed in future SCxxxx designs. It is recommended that a test of this field be included in all versions of firmware interface code.

The initial release of the SC4000 will be Version/Revision = 10H

**Configuration Register 5, IAR = 05H**

LBDR_[7:0]	C_[47:40]	Definition
[2:0]	[42:40]	Master PLL Reference Select [2:0]
3	43	Internal/External Master PLL Select
[5:4]	[45:44]	SCbus SREF_8K Source Select [1:0]
6	46	SCbus SREF_8K Output Enable
7	47	SCbus SCLK 8.192 MHz 62.5% duty cycle enable

**Master PLL Reference Select [2:0] (C\_[42:40]) (Read/Write)**

When C\_43=0 this field selects the reference for the Internal Master PLL.

000-> Free-run (Default)

001-> Free-run

010-> Free-run

011-> SREF\_8K

100-> REF\_8K\_0

101-> REF\_8K\_1

110-> REF\_8K\_2

111-> REF\_8K\_3

# Universal Timeslot Interchange

# SC4000

When C\_43=1 this field selects the reference for the External Master PLL which is output on REF\_8K\_OUT pin7.

- 000 ->Free-run (driven high) (Default)
- 001 ->Free-run (driven high)
- 010 ->Free-run (driven high)
- 011 -> SREF\_8K
- 100 -> REF\_8K\_0
- 101 -> REF\_8K\_1
- 110 -> tri-state (Z)
- 111 -> tri-state (Z)

**Internal/External Master PLL Select (C\_43) (Read/Write)**

This bit selects the Master PLL to be either Internal or External.

- 0 -> Internal Master PLL (Default)
- 1 -> External Master PLL

**SCbus SREF\_8K Source Select [1:0] (C\_[45:44]) (Read/Write)**

- 00 -> REF\_8K\_0 (Default)
- 01 -> REF\_8K\_1
- 10 -> REF\_8K\_2
- 11 -> REF\_8K\_3

**SCbus SREF\_8K Output Enable (C\_46) (Read/Write)**

- 0 -> SCbus SREF\_8K Disabled (Z) (Default)
- 1 -> SCbus SREF\_8K Enabled

**SCbus SCLK 8.192 MHz 62.5% Duty Cycle (C\_47) (Read/Write)**

- 0 -> SCLK 8.192 MHz 62.5% Duty Cycle Disabled (Default)
- 1 -> SCLK 8.192 MHz 62.5% Duty Cycle Enabled

**Note:** The SCbus Framing Mode (C\_[5:4]) must be set to 8.192 Mb/s to enable SCLK 8.192 MHz 62.5% duty cycle. If Enable (C\_22=0) SCLKX2N will be driven high.

**Configuration Register Byte 6, IAR = 06H**

LBDR_[7:0]	C_[55:48]	Definition
0	48	Clock Watchdog Enable
1	49	Microprocessor Watchdog Enable
2	50	SCbus CLKFAIL Latch Set Polarity Select
3	51	SCbus CLKFAIL Latch Debounce Enable
4	52	Frame Boundary Latch Set Delay Enable
5	53	INT_0 Mask_n
6	54	INT_0 Polarity
7	55	INT_0 Output Driver Configuration

**Clock Watchdog Enable (C\_48) (Read/Write)**

This bit enables the Clock Watchdog.

- 0 -> Clock Watchdog Disabled (Default)
- 1 -> Clock Watchdog Enabled

**Note:** When enabled, C\_48 is read back a 1 until the Master PLL clocks for 125us (+/- 50%); then it reads back a 0. This mode is provided to allow detection of a missing PLL clock. This information can then be used to take a master off the bus or to remove a secondary clock master from the fallback list. The Clock Watchdog must be re-armed after each test. To re-arm, the Clock Watchdog C\_48 must be cleared to "0" and then set to "1".

**Microprocessor Watchdog Enable (C\_49) (Read/Write)**

This bit enables the Microprocessor Watchdog.

- 0 -> Microprocessor Watchdog Disabled (Default)
- 1 -> Microprocessor Watchdog Enabled

**Note:** When enabled the SC4000 will be put into reset after the Master PLL clocks for 256 ms (+/-50%).

This mode is provided to force an SC4000 off the SCbus when it's controlling microprocessor fail to reset the watchdog. Each time C\_49 is cleared "0" and the set "1" the watchdog count is reset.

**SCbus CLKFAIL Latch Set Polarity Select (C\_50) (Read/Write)**

This bit selects the polarity of the SCbus CLKFAIL signal that will set the CLKFAIL latch.

- 0 -> CLKFAIL latch set when CLKFAIL = 0 (Default)
- 1 -> CLKFAIL latch set when CLKFAIL = 1

**Note 1:** The CLKFAIL polarity bit can be used to generate interrupts on both ends of a CLKFAIL transition. The CLKFAIL = 0 interrupt is used by the new primary clock source to determine that the transition from secondary to primary has been made. The CLKFAIL = 1 interrupt is used by a secondary clock source to determine that the primary clock source has given up the bus. A third module (neither primary or secondary) could use this interrupt to monitor the CLK-FAIL transition and act as a system watchdog.

**Note 2:** Only change CLKFAIL polarity when CLKFAIL Latch Clear\_N (C\_60) = 0.

**SCbus CLKFAIL Latch Debounce Enable (C\_51) (Read/Write)**

- 0 -> CLKFAIL Latch Debounce Disabled (Default)
- 1 -> CLKFAIL Latch Debounce Enabled

**Note 1:** A clock must be present from the Master PLL to enable this feature.

**Note 2:** The debounce logic requires that the CLKFAIL signal be sampled with the same value for two consecutive Master PLL clocks before it can set the CLK-FAIL Latch.

## Universal Timeslot Interchange

## SC4000

**Frame Boundary Latch Set Delay Enable (C\_52) (Read/Write)**

0 -> Frame Boundary Latch Set at frame boundary - no delay (Default)

1 -> Frame Boundary Latch Set is delayed until after the input buffer to output buffer transfer is complete (4 internal clocks after frame boundary).

**Note 1:** With direct W/R to Parallel Access Register Enabled (C\_11=1), using the delayed frame boundary interrupt indicates that it is now safe to read from and write to the Parallel Access Registers. To avoid data corruption, all access must be completed 8 internal clocks prior to the next delayed frame boundary interrupt.

**Note 2:** The internal clock is equal to either the SCbus data rate or the Local bus data rate whichever is faster.

**INT\_0 Mask\_N (C\_53) (Read/Write)**

Clearing this bit("0") masks INT\_0.

INT\_0 is the logical OR of CLKFAIL (C\_56), Frame Boundary (C\_57), Internal Master PLL Error (C\_58) Latches and SCbus Error (C\_59) Indicator.

0 -> INT\_0 Masked (Default)

1 -> INT\_0 Enabled

**Note:** The INT\_0 Mask bit can be used to globally disable interrupt generation while the state of the latches can continue to be polled through the micro-processor interface. This bit can also be used to create edge-triggered interrupts.

**INT\_0 Output Polarity (C\_54) (Read/Write)**

0 -> INT\_0 Active Low (Default)

1 -> INT\_0 Active High

**INT\_0 Output Driver (C\_55) (Read/Write)**

0 -> Open Collector INT\_0 Output Driver (Default)

1 -> Totem-Pole INT\_0 Output Driver

**Configuration Register Byte 7, IAR = 07H**

LBDR_[7:0]	C_[63:56]	Definition
0	56	SCbus CLKFAIL Latch (Read only)
1	57	Frame Boundary Latch (Read only)
2	58	Internal Master PLL Error Latch (Read only)
3	59	SCbus Error Indicator (Read only)
4	60	SCbus CLKFAIL Latch Clear_n
5	61	Frame Boundary Latch Clear_n
6	62	Internal Master PLL Error Latch Clear_n
7	63	Reserved (0) (Read only)

**SCbus CLKFAIL Latch (C\_56) (Read Only)**

0 -> SCbus CLKFAIL Latch Clear

1 -> SCbus CLKFAIL Latch Set

**Frame Boundary Latch (C\_57) (Read only)**

0 -> Frame Boundary Latch Clear

1 -> Frame Boundary Latch Set

**Internal Master PLL Error Latch (C\_58) (Read Only)**

This latch is set when the Internal Master PLL is not "locked" to its selected reference.

0 -> Internal Master PLL Error Latch Clear

1 -> Internal Master PLL Error Latch Set

**SCbus Error Indicator (C\_59) (Read Only)**

C\_59 is the logical OR of C\_[67:64], C\_[74:72] and C\_[83:80].

0 -> All SCbus Error Latches Clear

1 -> one or more SCbus Error Latches Set

**SCbus CLKFAIL Latch Clear\_N (C\_60) (Read/Write)**

0 -> SCbus CLKFAIL Latch held clear (Default)

1 -> SCbus CLKFAIL Latch enabled

**Frame Boundary Latch Clear\_N (C\_61) (Read/Write)**

0 -> Frame Boundary Latch held clear (Default)

1 -> Frame Boundary Latch enabled

**Internal Master PLL Error Latch Clear\_N (C\_62) (Read/Write)**

0 -> Internal Master PLL Error Latch held clear (Default)

1 -> Internal Master PLL Error Latch enabled

**Configuration Register Byte 8, IAR = 08H**

LBDR_[7:0]	C_[71:64]	Definition
0	64	SCbus SCLKX2N Error Latch (Read only)
1	65	SCbus SCLKX2NA Error Latch (Read only)
2	66	SCbus SCLK Error Latch (Read only)
3	67	SCbus SCLKA Error Latch (Read only)
4	68	SCbus SCLKX2N Error Latch Clear_n
5	69	SCbus SCLKX2NA Error Latch Clear_n
6	70	SCbus SCLK Error Latch Clear_n
7	71	SCbus SCLKA Error Latch Clear_n

**SCbus SCLKX2N Error Latch (C\_64) (Read Only)**

The SCbus SCLKX2N Error Latch is set when SCLKX2N does not transition during the equivalent Master PLL clock period.

0 -> SCbus SCLKX2N Error Latch Clear

1 -> SCbus SCLKX2N Error Latch Set

# Universal Timeslot Interchange

# SC4000

**SCbus SCLKX2NA Error Latch (C\_65)**

(Read only)

The SCbus SCLKX2NA Error Latch is set when SCLKX2NA does not transition during the equivalent Master PLL clock period.

0 -> SCbus SCLKX2NA Error Latch Clear

1 -> SCbus SCLKX2NA Error Latch Set

**SCbus SCLK Error Latch (C\_66) (Read only)**

The SCbus SCLK Error Latch is set when SCLK does not transition during the equivalent Master PLL clock period.

0 -> SCbus SCLK Error Latch Clear

1 -> SCbus SCLK Error Latch Set

**SCbus SCLKA Error Latch (C\_67) (Read only)**

The SCbus SCLKA Error Latch is set when SCLKA does not transition during the equivalent Master PLL clock period.

0 -> SCbus SCLKA Error Latch Clear

1 -> SCbus SCLKA Error Latch Set

**SCbus SCLKX2N Error Latch Clear\_N (C\_68)**

(Read/Write)

0 ->SCbus SCLKX2N Error Latch held clear (Default)

1 ->SCbus SCLKX2N Error Latch enabled

**SCbus SCLKX2NA Error Latch Clear\_N (C\_69) (Read/Write)**

0 ->SCbus SCLKX2NA Error Latch held clear (Default)

1 ->SCbus SCLKX2NA Error Latch enabled

**SCbus SCLK Error Latch Clear\_N (C\_70)**

(Read/Write)

0 ->SCbus SCLK Error Latch held clear (Default)

1 ->SCbus SCLK Error Latch enabled

**SCbus SCLKA Error Latch Clear\_N(C\_71)**

(Read/Write)

0 ->SCbus SCLKA Error Latch held clear (Default)

1 ->SCbus SCLKA Error Latch enabled

**Configuration Register Byte 9, IAR = 09H**

LBDR_[7:0]	C_[79:72]	Definition
0	72	SCbus FSYNCN Error Latch (Read Only)
1	73	SCbus FSYNCNA Error Latch (Read Only)
2	74	SCbus Clock Master Error Latch (Read Only)
3	75	Reserved (0) (Read Only)
4	76	SCbus FSYNCN Error Latch Clear_n
5	77	SCbus FSYNCNA Error Latch Clear_n
6	78	SCbus Clock Master Error Latch Clear_n
7	79	Reserved (0) (Read Only)

**SCbus FSYNCN Error Latch (C\_72)**

(Read Only)

The SCbus FSYNCN Error Latch is set when FSYNCN does not transition during the equivalent Master PLL clock period.

0 ->SCbus FSYNCN Error Latch Clear

1 ->SCbus FSYNCN Error Latch Set

**SCbus FSYNCNA Error Latch (C\_73)**

(Read Only)

The SCbus FSYNCNA Error Latch is set when FSYNCNA does not transition during the equivalent Master PLL clock period.

0 ->SCbus FSYNCNA Error Latch Clear

1 ->SCbus FSYNCNA Error Latch Set

**SCbus Clock Master Error Latch (C\_74)**

(Read Only)

The SCbus Clock Master Error Latch is set when the SC4000 is configured to be Clock Master and the internally generated frame sync signal and SCbus FSYNCN are not equal. This feature is provided to detect when more than one SCbus device is enabled as Clock Master

(i.e. two device driving FSYNCN).

0 ->SCbus Clock Master Error Latch Clear

1 ->SCbus Clock Master Error Latch Set

**SCbus FSYNCN Error Latch Clear\_N (C\_76)**

(Read/Write)

0 ->SCbus FSYNCN Error Latch held clear (Default)

1 ->SCbus FSYNCN Error Latch enabled

**SCbus FSYNCNA Error Latch Clear\_N (C\_77)**

(Read/Write)

0 ->SCbus FSYNCNA Error Latch held clear

1 ->SCbus FSYNCNA Error Latch enabled

**SCbus Clock Master Error Latch Clear\_N (C\_78) (Read/Write)**

(Read/Write)

0 ->SCbus Clock Master Error Latch held clear (Default)

1 ->SCbus Clock Master Error Latch enabled

**Configuration Register Byte 10, IAR = 0AH**

LBDR_[7:0]	C_[87:80]	Definition
0	80	SCbus SREF_8K NE SREF_8KA Error Latch (Read only)
1	81	SCbus CLKFAIL NE CLKFAILA Error Latch (Read only)
2	82	SCbus MC NE MCA Error Latch (Read only)
3	83	SCbus SD Error Indicator (Read only)
4	84	SCbus SREF_8K NE SREF_8KA Error Latch Clear_n
5	85	SCbus CLKFAIL NE CLKFAILA Error Latch Clear_n
6	86	SCbus MC NE MCA Error Latch Clear_n
7	87	SCbus SD Error Latch Clear_n

NE: Not Equal



# Universal Timeslot Interchange

# SC4000

**SCbus SREF\_8K NE SREF\_8KA Error Latch (C\_80)(Read only)**

The SCbus SREF\_8K NE SREF\_8KA Error Latch is set when SREF\_8K and SREF\_8KA are not equal for three consecutive Master PLL clocks.

0 ->SCbus SREF\_8K NE SREF\_8KA Error Latch Clear

1 ->SCbus SREF\_8K NE SREF\_8KA Error Latch Set

**SCbus CLKFAIL NE CLKFAILA Error Latch (C\_81)(Read only)**

The SCbus CLKFAIL NE CLKFAILA Error Latch is set when CLKFAIL and CLKFAILA are not equal for three consecutive Master PLL clocks.

0 ->SCbus CLKFAIL NE CLKFAILA Error Latch Clear

1 ->SCbus CLKFAIL NE CLKFAILA Error Latch Set

**SCbus MC NE MCA Error Latch (C\_82)(Read only)**

The SCbus MC NE MCA Error Latch is set when MC and MCA are not equal. MC\_CLK is used to sample the comparison.

0 ->SCbus MC NE MCA Error Latch Clear

1 ->SCbus MC NE MCA Error Latch Set

**SCbus SD Error Indicator (C\_83) (Read only)**  
C\_83 is the logical OR of C\_[103:88]

0 -> All SCbus SD Error Latches Clear

1 -> One or more SCbus SD Error Latch Set

**SCbus SREF\_8K NE SREF\_8KA Error Latch Clear\_N (C\_84)(Read/Write)**

0 ->SCbus SREF\_8K NE SREF\_8KA Error Latch held clear (Default)

1 ->SCbus SREF\_8K NE SREF\_8KA Error Latch enabled

**SCbus CLKFAIL NE CLKFAILA Error Latch Clear\_N (C\_85)(Read/write)**

0 ->SCbus CLKFAIL NE CLKFAILA Error Latch held clear (Default)

1 ->SCbus CLKFAIL NE CLKFAILA Error Latch enabled

**SCbus MC NE MCA Error Latch Clear\_N (C\_86)(Read/Write)**

0 ->SCbus MC NE MCA Error Latch held clear (Default)

1 ->SCbus MC NE MCA Error Latch enabled

**SCbus SD Error Latch Clear\_N (C\_87)(Read/Write)**

0 ->SCbus SD Error Latch held clear (Default)

1 ->SCbus SD Error Latch enabled

**Note:** C\_87 controls all 16 SD Error latches.

**Configuration Register Byte 11, IAR = 0BH**

LBDR_[7:0]	C_[95:88]	Definition
[7:0]	[95:88]	SCbus SD_[7:0] Error Latch (Read only)

**Configuration Register Byte 12, IAR = 0CH**

LBDR_[7:0]	C_[103:96]	Definition
[7:0]	[103:96]	SCbus SD_[15:8] Error Latch (Read only)

**SCbus SD\_[15:0] Error Latch (C\_[103:88])(Read only)**

An SCbus SD Error Latch is set when an SD output timeslot is enabled and the internally generated SD signal and SCbus are not equal. This feature is provided to detect when more than one SCbus device is enabled on the same timeslot. All SCbus SD Error Latches are enabled and cleared by C\_87.

**Note:** If multiple destination channels within the same SC4000 are enabled onto the same timeslot an error will not occur. Bus contention is prevented by logically "ANDing" the internal SD signals before they are output onto the SCbus SD.

**SUMMARY OF SC4000**

**CONFIGURATION REGISTERS**

**Miscellaneous**

Diagnostic Mode Enable (C\_3) (Read/Write)

Direct R/W to Parallel Access Registers Enable (C\_11) (Read/Write)

SC4000 Revision/Version Register (C\_[39:32]) (Read only)

**Master Clock/PLL**

Master Clock Input Frequency Select [2:0] (C\_[10:8]) (Read/Write)

Master PLL Reference Select [2:0] (C\_[42:40]) (Read/Write)

Internal/External Master PLL Select (C\_43) (Read/Write)

**SCbus (MVP Bus)**

SCbus Clock Master (C\_0) (Read/Write)

SCbus Clock Master Arm (C\_1) (Read/Write)

SCbus Primary/Alternate Select (C\_2) (Read/Write)

SCbus Framing Mode [1:0](C\_[5:4]) (Read/Write)

SCbus SD Sample Position (C\_16) (Read/Write)

SCbus SD Output Delay Enable (C\_18) (Read/Write)

SCbus FSYNCN Sample Position (C\_20) (Read/Write)

SCbus FSYNCN Rate (C\_21) (Read/Write)

SCbus SCLKX2N, SCLKX2NA Output Disable (C\_22) (Read/Write)

SCbus Alternate ("A") Signals Output Enable (C\_23) (Read/Write)

SCbus SREF\_8K Source Select [1:0] (C\_[45:44]) (Read/Write)

SCbus SREF\_8K Output Enable (C\_46) (Read/Write)

SCbus SCLK 8.192 MHz 62.5% Duty Cycle (C\_47) (Read/Write)

## Universal Timeslot Interchange

## SC4000

**Local Bus**

Local bus Framing Mode [1:0] (C\_[7:6])  
(Read/Write)

Local Bus SI Sample Position (C\_17)  
(Read/Write)

Local bus SO Output Delay Enable  
(C\_19) (Read/Write)

Local bus L\_CLK Polarity (C\_24)  
(Read/Write)

Local bus L\_FS Polarity (C\_25)  
(Read/Write)

Local bus L\_FS Position (C\_[27:26])  
(Read/Write)

Local bus L\_CLK & L\_FS Rate (C\_28)  
(Read/Write)

Local bus L\_CLK DPLL Enable (C\_29)  
(Read/Write)

Local bus L\_CLK 8.192 MHz 62.5%  
Duty Cycle (C\_30) (Read/Write)

**Message Channel**

Message Channel Registered TXD  
Enable (C\_12) (Read/Write)

Message Channel TXD\_0 or TXD\_1  
Select (C\_13) (Read/Write)

Message Channel Clock Duty Cycle  
Select (C\_14) (Read/Write)

Message Channel Output Disable  
(W/ loopback) (C\_15) (Read/Write)

**Watchdog**

Clock Watchdog Enable (C\_48)  
(Read/Write)

Microprocessor Watchdog Enable  
(C\_49) (Read/Write)

**Interrupt**

SCbus CLKFAIL Latch Set Polarity  
Select (C\_50) (Read/Write)

SCbus CLKFAIL Latch Debounce  
Enable (C\_51) (Read/Write)

Frame Boundary Latch Set Delay Enable  
(C\_52) (Read/Write)

INT\_0 Mask\_N (C\_53) (Read/Write)

INT\_0 Output Polarity (C\_54)  
(Read/Write)

INT\_0 Output Driver (C\_55)  
(Read/Write)

SCbus CLKFAIL Latch (C\_56)  
(Read Only)

Frame Boundary Latch (C\_57)  
(Read only)

Internal Master PLL Error Latch (C\_58)  
(Read Only)

SCbus Error Indicator (C\_59)  
(Read Only)

SCbus CLKFAIL Latch Clear\_N (C\_60)  
(Read/Write)

Frame Boundary Latch Clear\_N (C\_61)  
(Read/Write)

Internal Master PLL Error Latch  
Clear\_N (C\_62) (Read/Write)

SCbus SCLKX2N Error Latch (C\_64)  
(Read Only)

SCbus SCLKX2NA Error Latch (C\_65)  
(Read only)

SCbus SCLK Error Latch (C\_66)  
(Read only)

SCbus SCLKA Error Latch (C\_67)  
(Read only)

SCbus SCLKX2N Error Latch Clear\_N  
(C\_68) (Read/Write)

SCbus SCLKX2NA Error Latch Clear\_N  
(C\_69) (Read/Write)

SCbus SCLK Error Latch Clear\_N  
(C\_70) (Read/Write)

SCbus SCLKA Error Latch  
Clear\_N(C\_71) (Read/Write)

SCbus FSYNCN Error Latch (C\_72)  
(Read Only)

SCbus FSYNCNA Error Latch (C\_73)  
(Read Only)

SCbus Clock Master Error Latch (C\_74)  
(Read Only)

SCbus FSYNCN Error Latch Clear\_N  
(C\_76) (Read/Write)

SCbus FSYNCNA Error Latch Clear\_N  
(C\_77) (Read/Write)

SCbus Clock Master Error Latch  
Clear\_N (C\_78) (Read/Write)

SCbus SREF\_8K NE SREF\_8KA Error  
Latch (C\_80)(Read only)

SCbus CLKFAIL NE CLKFAILA Error  
Latch (C\_81)(Read only)

SCbus MC NE MCA Error Latch  
(C\_82)(Read only)

SCbus SD Error Indicator (C\_83)  
(Read only)

SCbus SREF\_8K NE SREF\_8KA Error  
Latch Clear\_N (C\_84)(Read/Write)

SCbus CLKFAIL NE CLKFAILA Error  
Latch Clear\_N (C\_85)(Read/write)

SCbus MC NE MCA Error Latch  
Clear\_N (C\_86)(Read/Write)

SCbus SD Error Latch Clear\_N  
(C\_87)(Read/Write)

SCbus SD\_[15:0] Error Latch  
(C\_[103:88]) (Read only)

**Reserved Bit**

No use Bit (C\_31) (Read only)

No use Bit (C\_63) (Read only)

No use Bit (C\_75) (Read only)

No use Bit (C\_79) (Read only)

**TYPICAL INTERNAL REGISTER ACCESS****Typical Write Internal Register Access**

1. Read Command/Status register and test for NOT BUSY. (Note1)
2. Write Data into Internal Address register, Low Byte Data register, and High Byte Data register as required.
3. Write a "1" to the WRITE Command bit in the Command/Status register. (Note 4)
4. Read Command/Status register and test for NOT BUSY. (Note 2)

**Typical Read Internal Register Access**

1. Read Command/Status register and test for NOT BUSY. (Note 1)
2. Write Data into Internal Address register.
3. Write a "1" to the READ Command bit in the Command/Status register. (Note 3 & 4)

# Universal Timeslot Interchange

# SC4000

- 4. Read Command/Status register and test for NOT BUSY. (Note2)
- 5. Read contents of Low Byte Data register and High Byte Data register as required.

**Note 1:**It is not necessary to test for NOT BUSY in this step if the protocol used to access the SC4000 does not allow the previous command to be completed until the Command/Status register indicates NOT BUSY.

**Note 2:**It is not necessary to test for NOT BUSY in this step if the Command given does not require synchronization or if the protocol used to access the SC4000 allows a command to be completed while the Command/Status register indicates BUSY.

**Note 3:**It is not necessary to execute this step if the Command given does not require synchronization.

**Note 4:**The Channel Bank Select field may be changed during the same write cycle which issues a command. The command will effect the register pointed to by the new value in the Channel Bank Select Field.

**Test**  
The Nand gate test chain is enabled by forcing the TEST pin "high". When in test mode each pin is "nanded" with the preceding pin and output at the end of chain.

X_IN	D_0
REF_8K_0	D_1
REF_8K_1	D_2
REF_8K_2	D_3
REF_8K_3	D_4
TXD_0	D_5
RXD	D_6
MC_CLK	D_7
I_N	SCLKX2N
INT_0	SCLKX2NA
INT_1	SCLK
CS_0_N	SCLKA
CS_1_N	SREF_8K
RD_N	SREF_8KA
WR_N	FSYNCN
DACK_N	FSYNCNA
ALE	CLKFAIL
A_0	CLKFAILA
A_1	SD_0
A_2	SD_1
A_3	SD_2
A_4	SD_3

A_5	SD_4
A_6	SD_5
A_7	SD_6
A_8	SD_7
↓	SD_8
DRQ_R	SD_9
	SD_10
	SD_11
	SD_12
	SD_13
	SD_14
	SD_15
	MC
	MCA
	L_CLK
	L_FS
	SO_0
	SO_1
	SO_2
	SO_3
	SI_0
	SI_1
	SI_2
	SI_3
	RESET
	↓
	DRQ_T

## Universal Timeslot Interchange

## SC4000

## ELECTRICAL SPECIFICATIONS

## Absolute Maximum Ratings

Symbol	Parameter	Test Condition	Min	Max	Unit
$T_S$	Storage Temperature		-65	150	$^{\circ}\text{C}$
$V_i$	Input Voltage		-0.5	7	V
$P_D$	Package Power Dissipation			1	W

## Recommended Operating Conditions

Symbol	Parameter	Test Condition	Min	Max	Unit
$T_A$	Ambient Temperature		0	70	$^{\circ}\text{C}$
$V_{DD}$	Supply Voltage		4.75	5.25	V

## DC Electrical Characteristic

Symbol	Parameter	Test Condition	Min	Max	Unit
$I_{DD}$	Supply Current			100	mA
$V_{IH-SCbus}$	Input High Voltage - SCbus		2.6	$V_{DD} + 0.5$	V
$V_{IL-SCbus}$	Input Low Voltage - SCbus		-0.5	1.65	V
$V_{HYS-SCbus}$	Input Hysteresis Voltage-SCbus		+/- 0.3		V
$V_{IH-TTL}$	Input High Voltage -TTL		2.0	$V_{DD} + 0.5$	V
$V_{IL-TTL}$	Input Low Voltage -TTL		-0.5	0.8	V
$V_{IH-CMOS}$	Input High Voltage -CMOS		$0.7 \times V_{DD}$	$V_{DD} + 0.5$	V
$V_{IL-CMOS}$	Input Low Voltage -CMOS		-0.5	$0.3 \times V_{DD}$	V
$V_{OH-SCbus}$	Output High Voltage -SCbus	$I_{OH} = -24\text{mA}$	3		V
$V_{OL-SCbus}$	Output Low Voltage -SCbus	$I_{OL} = 24\text{mA}$		0.4	V
$V_{OH-TTL}$	Output High Voltage-TTL	$I_{OH} = -8\text{mA}$	2.4		V
$V_{OL-TTL}$	Output Low Voltage-TTL	$I_{OL} = 8\text{mA}$		0.4	V
$V_{OH-CMOS}$	Output High Voltage-CMOS	$I_{OH} = -0.8\text{mA}$	$V_{DD} - 0.1\text{V}$		V
$V_{OL-CMOS}$	Output Low Voltage-CMOS	$I_{OL} = 0.8\text{mA}$		$V_{SS} + 0.1\text{V}$	V
$I_P-SCbus$	Pull-up Current - SCbus	$V_{PAD} = 0\text{V}$	-20	-50	$\mu\text{A}$
$I_P-TTL$	Pull-up Current - TTL	$V_{PAD} = 0\text{V}$	-130	-400	$\mu\text{A}$
$I_{L/I/O}$	I/O Leakage Current	$V_{I/O} = V_{DD}$ or $V_{SS}$		+/- 10	$\mu\text{A}$
$C_i-TTL$	Input Capacitance-TTL			6	pF
$C_i-CMOS$	Input Capacitance-CMOS			7	pF
$C_{iO-SCbus}$	I/O Capacitance-SCbus			12	pF
$C_{iO-TTL}$	Output or I/O Capacitance - TT			7	pF
$C_O-CMOS$	Output Capacitance - CMOS			6	pF

# Universal Timeslot Interchange

# SC4000

## AC ELECTRICAL CHARACTERISTICS

Figure 7. Microprocessor Interface Timing - Intel Bus Mode (Pin I\_N = 0), Non-Multiplexed Address

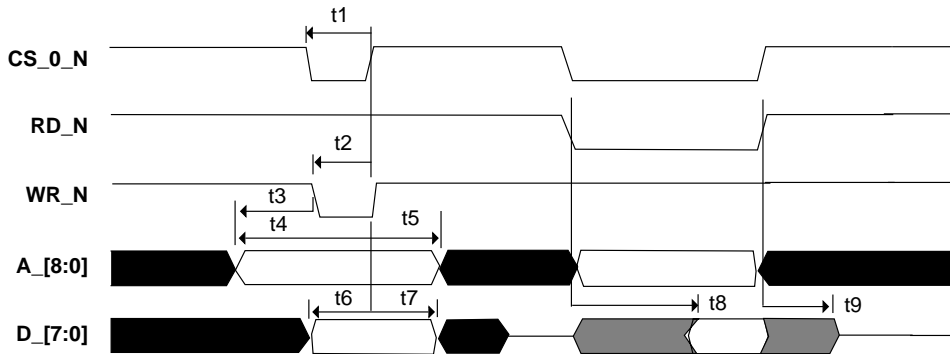

Table 7. Microprocessor Interface Timing - Intel Bus Mode

Symbol	Parameter	Min	Typ	Max	Unit
t1	CS_0_N setup to WR_N ↑	40			ns
t2	WR_N pulse width	40			ns
t3	A_[8:0] setup to WR_N ↓ (C_11 = 1)	5			ns
t4	A_[1:0] setup to WR_N ↑ (C_11 = 0)	40			ns
t5	A_[8:0] hold from WR_N ↑	5			ns
t6	D_[7:0] setup to WR_N ↑	40			ns
t7	D_[7:0] hold from WR_N ↑	5			ns
t8	D_[7:0] float to valid delay from CS_0_N, RD_N and A_[8:0]	0		50	ns
t9	D_[7:0] valid to float delay from CS_0_N or RD_N	0		20	ns

- Notes**
1. Timing measured with 100 pF load on D\_[7:0].
  2. Write cycle may be controlled by CS\_0\_N or WR\_N.
  3. ALE = 1.

Universal Timeslot Interchange

SC4000

Figure 8. Microprocessor Interface Timing - Motorola Bus Mode (Pin L<sub>N</sub> = 1), Non-multiplexed Address

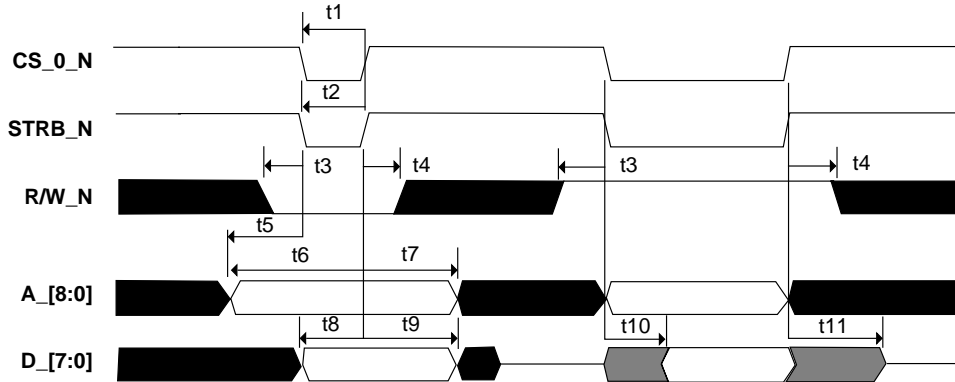

Table 8. Microprocessor Interface Timing - Intel Bus Mode

Symbol	Parameter	Min	Typ	Max	Unit
t1	CS <sub>0_N</sub> setup to STRB <sub>N</sub> ↑	40			ns
t2	STRB <sub>N</sub> pulse width	40			ns
t3	R/W <sub>N</sub> setup to STRB <sub>N</sub> ↓	5			ns
t4	R/W <sub>N</sub> hold from STRB <sub>N</sub> ↑	5			ns
t5	A <sub>[8:0]</sub> setup to STRB <sub>N</sub> ↓ (C <sub>11</sub> = 1)	5			ns
t6	A <sub>[1:0]</sub> setup to STRB <sub>N</sub> ↑ (C <sub>11</sub> = 0)	40			ns
t7	A <sub>[8:0]</sub> hold from STRB <sub>N</sub> ↑	5			ns
t8	D <sub>[7:0]</sub> setup to STRB <sub>N</sub> ↑	40			ns
t9	D <sub>[7:0]</sub> hold from STRB <sub>N</sub> ↑	5			ns
t10	D <sub>[7:0]</sub> float to valid delay from CS <sub>0_N</sub> , STRB <sub>N</sub> and A <sub>[8:0]</sub>	0		50	ns
t11	D <sub>[7:0]</sub> valid to float delay from CS <sub>0_N</sub> or STRB <sub>N</sub>	0		20	ns

- Notes
1. Timing measured with 100 pF load on D<sub>[7:0]</sub>.
  2. Write cycle may be controlled by CS<sub>0\_N</sub> or STRB<sub>N</sub>.
  3. ALE = 1.

Universal Timeslot Interchange

SC4000

Figure 9. Microprocessor Interface Timing - Multiplexed Address

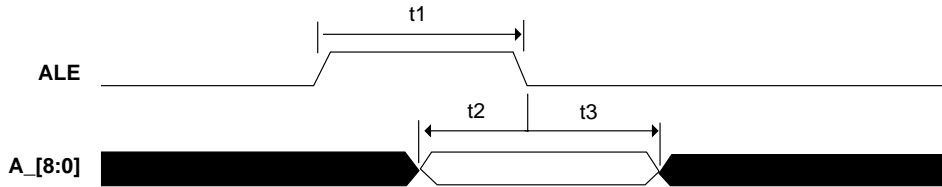

Table 9. Microprocessor Interface Timing - Multiplexed Address

Symbol	Parameter	Min	Typ	Max	Unit
t1	ALE pulse width	20			ns
t2	A_[8:0] setup to ALE ↓	5			ns
t3	A_[8:0] hold from ALE ↓	5			ns

# Universal Timeslot Interchange

# SC4000

Figure 10. Local Bus Timing, 1XL\_CLK Mode (C\_28 = 0)

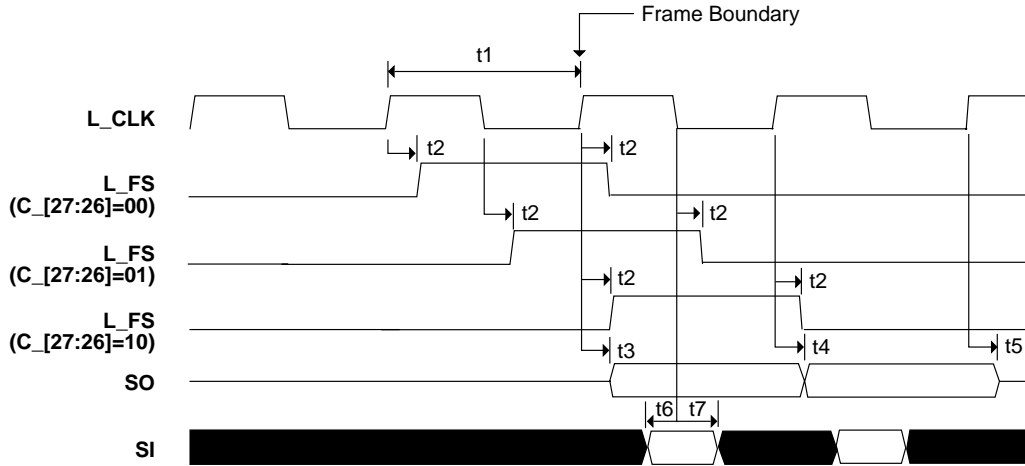

Table 10. Local Bus Timing, 1X L\_CLK Mode (C\_28 = 0)

Symbol	Parameter	Min	Typ	Max	Unit
t1a	L_CLK Period (C_[7:6] = 0X)		488		ns
t1b	L_CLK Period (C_[7:6] = 10)		244		ns
t1c	L_CLK Period (C_[7:6] = 11)		122		ns
t2a	L_FS delay from L_CLK (C_29 = 0)	0		10	ns
t2b	L_FS delay from L_CLK (C_[7:6] = 0X, C_29 = 1)	-15		25	ns
t3a	SO_[3:0] float to valid delay from L_CLK ↑ (C_19 = 0, C_29 = 0)	0		10	ns
t3b	SO_[3:0] float to valid delay from L_CLK ↑ (C_19 = 0, C_[7:6] = 0X, C_29 = 1)	-15		25	ns
t3c	SO_[3:0] float to valid delay from L_CLK ↑ (C_19 = 1, C_[7:6] = 0X, C_29 = 0)	25		60	ns
t3d	SO_[3:0] float to valid delay from L_CLK ↑ (C_19 = 1, C_[7:6] = 0X, C_29 = 1)	10		75	ns
t3e	SO_[3:0] float to valid delay from L_CLK ↑ (C_19 = 1, C_[7:6] = 10)	25		60	ns
t3f	SO_[3:0] float to valid delay from L_CLK ↑ (C_19 = 1, C_[7:6] = 11)	10		30	ns
t4a	SO_[3:0] valid to valid delay from L_CLK ↑ (C_29 = 0)	0		10	ns
t4b	SO_[3:0] valid to valid delay from L_CLK ↑ (C_[7:6] = 0X, C_29 = 1)	-15		25	ns
t5a	SO_[3:0] valid to float delay from L_CLK ↑ (C_29 = 0)	0		10	ns
t5b	SO_[3:0] valid to float delay from L_CLK ↑ (C_[7:6] = 0X, C_29 = 1)	-15		25	ns
t6a	SI_[3:0] setup to L_CLK ↓ (C_17 = 0, C_29 = 0)	10			ns
t6b	SI_[3:0] setup to L_CLK ↓ (C_17 = 0, C_[7:6] = 0X, C_29 = 1)	25			ns
t7a	SI_[3:0] hold from L_CLK ↓ (C_17 = 0, C_29 = 0)	10			ns
t7b	SI_[3:0] hold from L_CLK ↓ (C_17 = 0, C_[7:6] = 0X, C_29 = 1)	25			ns

- Notes**
1. Timing measured with 100 pF load on all Local Bus outputs.
  2. L\_CLK and L\_FS shown with positive polarity, timing is equivalent when signals are inverted.



# Universal Timeslot Interchange

# SC4000

Figure 11. Local Bus Timing, 2X L\_CLK Mode (C\_28=1)

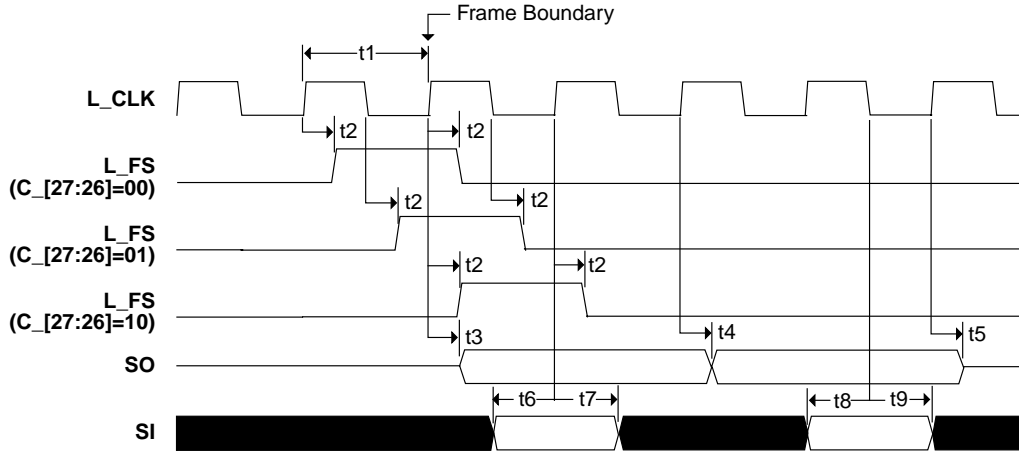

Table 11. Local Bus Timing, 2X L\_CLK Mode (C\_28 = 1)

Symbol	Parameter	Min	Typ	Max	Unit
t1a	L_CLK Period (C_[7:6] = 0X)		244		ns
t1b	L_CLK Period (C_[7:6] = 10)		122		ns
t1c	L_CLK Period (C_[7:6] = 11)		61		ns
t2a	L_FS delay from L_CLK ↑(C_29 = 0)	0		10	ns
t2b	L_FS delay from L_CLK ↑(C_[7:6] = 0X, C_29 = 1)	-15		25	ns
t3a	SO_[3:0] float to valid delay from L_CLK ↑(C_19 = 0, C_29 = 0)	0		10	ns
t3b	SO_[3:0] float to valid delay from L_CLK ↑(C_19 = 0, C_[7:6] = 0X, C_29 = 1)	-15		25	ns
t3c	SO_[3:0] float to valid delay from L_CLK ↑(C_19 = 1, C_[7:6] = 0X, C_29 = 0)	25		60	ns
t3d	SO_[3:0] float to valid delay from L_CLK ↑(C_19 = 1, C_[7:6] = 0X, C_29 = 1)	10		75	ns
t3e	SO_[3:0] float to valid delay from L_CLK ↑(C_19 = 1, C_[7:6] = 10)	25		60	ns
t3f	SO_[3:0] float to valid delay from L_CLK ↑(C_19 = 1, C_[7:6] = 11)	10		30	ns
t4a	SO_[3:0] valid to valid delay from L_CLK ↑(C_29 = 0)	0		10	ns
t4b	SO_[3:0] valid to valid delay from L_CLK ↑(C_[7:6] = 0X, C_29 = 1)	-15		25	ns
t5a	SO_[3:0] valid to float delay from L_CLK ↑(C_29 = 0)	0		10	ns
t5b	SO_[3:0] valid to float delay from L_CLK ↑(C_[7:6] = 0X, C_29 = 1)	-15		25	ns
t6a	SI_[3:0] setup to L_CLK ↑(C_17 = 0, C_29 = 0)	10			ns
t6b	SI_[3:0] setup to L_CLK ↑(C_17 = 0, C_[7:6] = 0X, C_29 = 1)	25			ns
t7a	SI_[3:0] hold from L_CLK ↑(C_17 = 0, C_29 = 0)	10			ns
t7b	SI_[3:0] hold from L_CLK ↑(C_17 = 0, C_[7:6] = 0X, C_29 = 1)	25			ns
t8a	SI_[3:0] setup to L_CLK ↓(C_17 = 1, C_29 = 0)	10			ns
t8b	SI_[3:0] setup to L_CLK ↓(C_17 = 1, C_[7:6] = 0X, C_29 = 1)	25			ns
t9a	SI_[3:0] hold from L_CLK ↓(C_17 = 1, C_29 = 0)	10			ns
t9b	SI_[3:0] hold from L_CLK ↓(C_17 = 1, C_[7:6] = 0X, C_29 = 1)	25			ns

- Notes
1. Timing measured with 100 pF load on all Local Bus outputs.
  2. L\_CLK and L\_FS shown with positive polarity, timing is equivalent when signals are inverted.

# Universal Timeslot Interchange

# SC4000

Figure 12. SCbus Timing

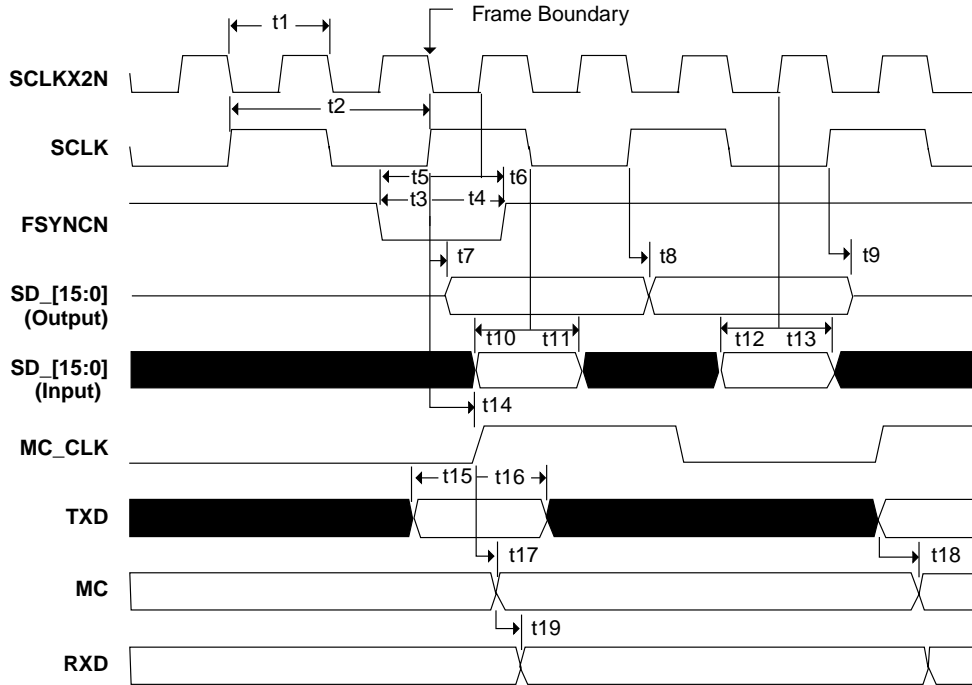

Table 12. SCbus Timing

Symbol	Parameter	Min	Typ	Max	Unit
t1a	SCLKX2N Period (C_[5:4] = 0X)		244		ns
t1b	SCLKX2N Period (C_[5:4] = 10)		122		ns
t1c	SCLKX2N Period (C_[5:4] = 11)		61		ns
t2a	SCLK Period (C_[5:4] = 0X)		488		ns
t2b	SCLK Period (C_[5:4] = 10)		244		ns
t2c	SCLK Period (C_[5:4] = 11)		122		ns
t3	FSYNCN setup to SCLK $\uparrow$ (C_20 = 0)	10			ns
t4	FSYNCN hold from SCLK $\uparrow$ (C_20 = 0)	10			ns
t5	FSYNCN setup to SCLKX2N $\uparrow$ (C_20 = 1)	10			ns
t6	FSYNCN hold from SCLKX2N $\uparrow$ (C_20 = 1)	10			ns
t7a	SD_[15:0] float to valid delay from SCLK $\uparrow$ (C_18 = 0)	0		15	ns
t7b	SD_[15:0] float to valid delay from SCLK $\uparrow$ (C_18 = 1, C_[5:4] = 0X)	25		60	ns
t7c	SD_[15:0] float to valid delay from SCLK $\uparrow$ (C_18 = 1, C_[5:4] = 10)	25		60	ns
t7d	SD_[15:0] float to valid delay from SCLK $\uparrow$ (C_18 = 1, C_[5:4] = 11)	10		30	ns
t8	SD_[15:0] valid to valid delay from SCLK $\uparrow$	0		15	ns
t9	SD_[15:0] valid to float delay from SCLK $\uparrow$	0		15	ns

## Universal Timeslot Interchange

## SC4000

Symbol	Parameter	Min	Typ	Max	Unit
t10	SD_[15:0] setup to SCLK ↓ (C_16 = 0)	10			ns
t11	SD_[15:0] hold from SCLK ↓ (C_16 = 0)	10			ns
t12	SD_[15:0] setup to SCLKX2N ↑ (C_16 = 1)	10			ns
t13	SD_[15:0] hold from to SCLKX2N ↑ (C_16 = 1)	10			ns
t14	MC_CLK delay from SCLK	0		15	ns
t15	TXD setup to MC_CLK ↑ (C_12 = 1)	10			ns
t16	TXD hold from MC_CLK ↑ (C_12 = 1)	10			ns
t17	MC delay from MC_CLK ↑ (C_12 = 1)	0		75	ns
t18	MC delay from TXD (C_12 = 0)	0		75	ns
t19	RXD delay from MC	0		15	ns

**Notes**

1. Timing measured with 100 pF load on all Local Bus outputs, 200 pF load on all SCbus outputs.
2. MC timing measured with 200 pF, 470 Ω pull-up (4.7 kΩ/10). Open collector low to high transitions include 15 ns + 60 ns delay from hi-Z to 3 V.
3. Timing is equivalent when Alternate SCbus signals are selected (C\_2=1).

Universal Timeslot Interchange

SC4000

Figure 13. SCbus Clock Master Timing

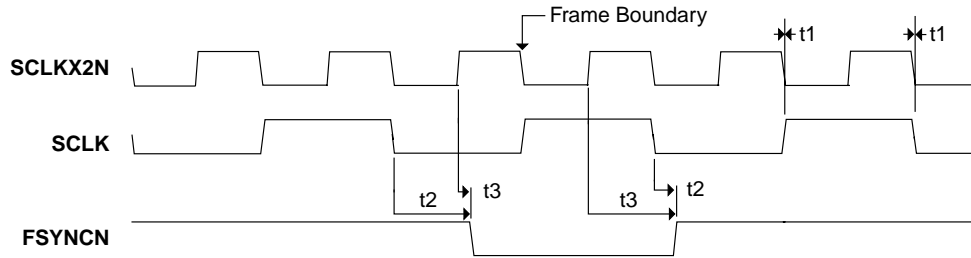

Table 13. SCbus Clock Master Timing

Symbol	Parameter	Min	Typ	Max	Unit
t1	SCLK to SCLKX2N Skew	-5		5	ns
t2	FSYNCN delay from SCLK ↓ (C_21 = 0)	0		10	ns
t3	FSYNCN delay from SCLKX2N ↑ (C_21 = 1)	0		10	ns

Note 1. Timing measured with 200 pF load on all SCbus outputs.

Universal Timeslot Interchange

SC4000

Figure 14. SCbus Clock Fail Timing

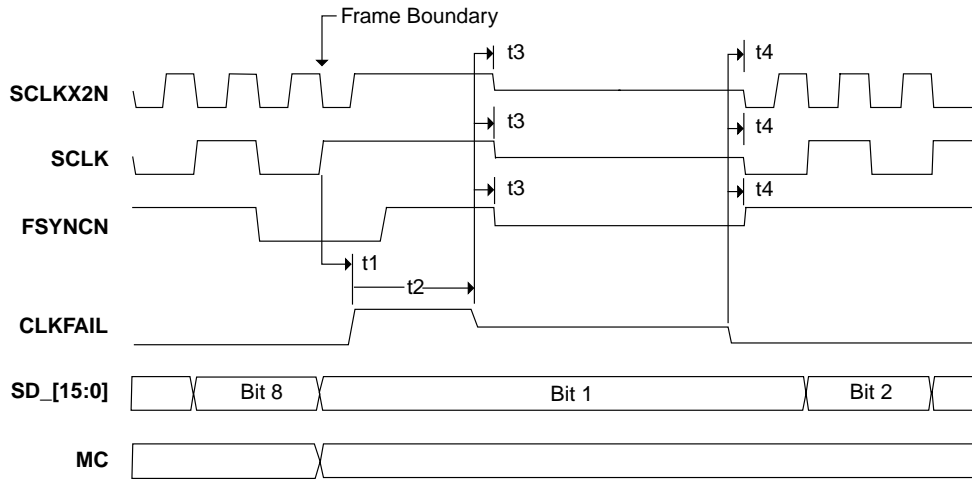

Table 14. SCbus Clock Fail Timing

Symbol	Parameter	Min	Typ	Max	Unit
t1	CLKFAIL delay from SCLK ↑	-5		5	ns
t2a	CLKFAIL period (C_[5:4] = 0X)		488		ns
t2b	CLKFAIL period (C_[5:4] = 10)		244		ns
t2c	CLKFAIL period (C_[5:4] = 11)		122		ns
t3	SCLKX2N, SCLK, FSYNCN float delay from CLKFAIL float			15	ns
t4	SCLKX2N, SCLK, FSYNCN valid delay from CLKFAIL ↓			10	ns

Note 1. Timing measured with 200 pF load on all SCbus outputs.

# Universal Timeslot Interchange

# SC4000

Figure 15. REF\_8K\_[3:0] and SREF\_8K input mode Timing

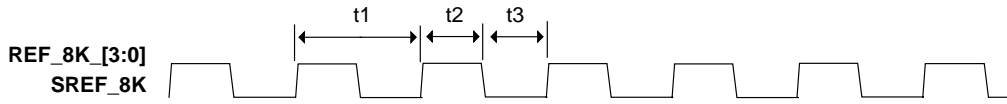

Table 15. REF\_8K\_[3:0] and SREF\_8K Timing

Symbol	Parameter	Min	Typ	Max	Unit
t1	REF_8K_[3:0] or SREF_8K period		125		μs
t2	REF_8K_[3:0] or SREF_8K high time	100			ns
t3	REF_8K_[3:0] or SREF_8K low time	100			ns

Note 1. Timing measured with 200 pF load on all SCbus outputs.

## Universal Timeslot Interchange

## SC4000

### SOLDERING

#### Introduction to soldering surface mount packages

This text gives a very brief insight to a complex technology. A more in-depth account of soldering ICs can be found in our *"Data Handbook IC26; Integrated Circuit Packages"* (document order number 9398 652 90011).

There is no soldering method that is ideal for all surface mount IC packages. Wave soldering can still be used for certain surface mount ICs, but it is not suitable for fine pitch SMDs. In these situations reflow soldering is recommended.

#### Reflow soldering

Reflow soldering requires solder paste (a suspension of fine solder particles, flux and binding agent) to be applied to the printed-circuit board by screen printing, stencilling or pressure-syringe dispensing before package placement.

Several methods exist for reflowing; for example, convection or convection/infrared heating in a conveyor type oven. Throughput times (preheating, soldering and cooling) vary between 100 and 200 seconds depending on heating method.

Typical reflow peak temperatures range from 215 to 250 °C. The top-surface temperature of the packages should preferably be kept below 220 °C for thick/large packages, and below 235 °C for small/thin packages.

#### Wave soldering

Conventional single wave soldering is not recommended for surface mount devices (SMDs) or printed-circuit boards with a high component density, as solder bridging and non-wetting can present major problems.

To overcome these problems the double-wave soldering method was specifically developed.

If wave soldering is used the following conditions must be observed for optimal results:

- Use a double-wave soldering method comprising a turbulent wave with high upward pressure followed by a smooth laminar wave.
- For packages with leads on two sides and a pitch (e):
  - larger than or equal to 1.27 mm, the footprint longitudinal axis is **preferred** to be parallel to the transport direction of the printed-circuit board;
  - smaller than 1.27 mm, the footprint longitudinal axis **must** be parallel to the transport direction of the printed-circuit board.

The footprint must incorporate solder thieves at the downstream end.

- For packages with leads on four sides, the footprint must be placed at a 45° angle to the transport direction of the printed-circuit board. The footprint must incorporate solder thieves downstream and at the side corners.

During placement and before soldering, the package must be fixed with a droplet of adhesive. The adhesive can be applied by screen printing, pin transfer or syringe dispensing. The package can be soldered after the adhesive is cured.

Typical dwell time is 4 seconds at 250 °C.

A mildly-activated flux will eliminate the need for removal of corrosive residues in most applications.

#### Manual soldering

Fix the component by first soldering two diagonally-opposite end leads. Use a low voltage (24 V or less) soldering iron applied to the flat part of the lead. Contact time must be limited to 10 seconds at up to 300 °C.

When using a dedicated tool, all other leads can be soldered in one operation within 2 to 5 seconds between 270 and 320 °C.

## Universal Timeslot Interchange

SC4000

## Suitability of surface mount IC packages for wave and reflow soldering methods

PACKAGE	SOLDERING METHOD	
	WAVE	REFLOW <sup>(1)</sup>
BGA, LFBGA, SQFP, TFBGA	not suitable	suitable
HBCC, HLQFP, HSQFP, HSOP, HTQFP, HTSSOP, SMS	not suitable <sup>(2)</sup>	suitable
PLCC <sup>(3)</sup> , SO, SOJ	suitable	suitable
LQFP, QFP, TQFP	not recommended <sup>(3)(4)</sup>	suitable
SSOP, TSSOP, VSO	not recommended <sup>(5)</sup>	suitable

## Notes

1. All surface mount (SMD) packages are moisture sensitive. Depending upon the moisture content, the maximum temperature (with respect to time) and body size of the package, there is a risk that internal or external package cracks may occur due to vaporization of the moisture in them (the so called popcorn effect). For details, refer to the Drypack information in the *"Data Handbook IC26; Integrated Circuit Packages; Section: Packing Methods"*.
2. These packages are not suitable for wave soldering as a solder joint between the printed-circuit board and heatsink (at bottom version) can not be achieved, and as solder may stick to the heatsink (on top version).
3. If wave soldering is considered, then the package must be placed at a 45° angle to the solder wave direction. The package footprint must incorporate solder thieves downstream and at the side corners.
4. Wave soldering is only suitable for LQFP, TQFP and QFP packages with a pitch (e) equal to or larger than 0.8 mm; it is definitely not suitable for packages with a pitch (e) equal to or smaller than 0.65 mm.
5. Wave soldering is only suitable for SSOP and TSSOP packages with a pitch (e) equal to or larger than 0.65 mm; it is definitely not suitable for packages with a pitch (e) equal to or smaller than 0.5 mm.



## Universal Timeslot Interchange

SC4000

## DATA SHEET STATUS

DATA SHEET STATUS	PRODUCT STATUS	DEFINITIONS <sup>(1)</sup>
Objective specification	Development	This data sheet contains the design target or goal specifications for product development. Specification may change in any manner without notice.
Preliminary specification	Qualification	This data sheet contains preliminary data, and supplementary data will be published at a later date. Philips Semiconductors reserves the right to make changes at any time without notice in order to improve design and supply the best possible product.
Product specification	Production	This data sheet contains final specifications. Philips Semiconductors reserves the right to make changes at any time without notice in order to improve design and supply the best possible product.

## Note

1. Please consult the most recently issued data sheet before initiating or completing a design.

## DEFINITIONS

**Short-form specification** — The data in a short-form specification is extracted from a full data sheet with the same type number and title. For detailed information see the relevant data sheet or data handbook.

**Limiting values definition** — Limiting values given are in accordance with the Absolute Maximum Rating System (IEC 60134). Stress above one or more of the limiting values may cause permanent damage to the device. These are stress ratings only and operation of the device at these or at any other conditions above those given in the Characteristics sections of the specification is not implied. Exposure to limiting values for extended periods may affect device reliability.

**Application information** — Applications that are described herein for any of these products are for illustrative purposes only. Philips Semiconductors make no representation or warranty that such applications will be suitable for the specified use without further testing or modification.

## DISCLAIMERS

**Life support applications** — These products are not designed for use in life support appliances, devices, or systems where malfunction of these products can reasonably be expected to result in personal injury. Philips Semiconductors customers using or selling these products for use in such applications do so at their own risk and agree to fully indemnify Philips Semiconductors for any damages resulting from such application.

**Right to make changes** — Philips Semiconductors reserves the right to make changes, without notice, in the products, including circuits, standard cells, and/or software, described or contained herein in order to improve design and/or performance. Philips Semiconductors assumes no responsibility or liability for the use of any of these products, conveys no licence or title under any patent, copyright, or mask work right to these products, and makes no representations or warranties that these products are free from patent, copyright, or mask work right infringement, unless otherwise specified.

# Universal Timeslot Interchange

SC4000

---

## NOTES

# Universal Timeslot Interchange

SC4000

---

## NOTES

# Philips Semiconductors – a worldwide company

**Argentina:** see South America

**Australia:** 3 Figtree Drive, HOMEBUSH, NSW 2140,  
Tel. +61 2 9704 8141, Fax. +61 2 9704 8139

**Austria:** Computerstr. 6, A-1101 WIEN, P.O. Box 213,  
Tel. +43 1 60 101 1248, Fax. +43 1 60 101 1210

**Belarus:** Hotel Minsk Business Center, Bld. 3, r. 1211, Volodarski Str. 6,  
220050 MINSK, Tel. +375 172 20 0733, Fax. +375 172 20 0773

**Belgium:** see The Netherlands

**Brazil:** see South America

**Bulgaria:** Philips Bulgaria Ltd., Energoproject, 15th floor,  
51 James Bourchier Blvd., 1407 SOFIA,  
Tel. +359 2 68 9211, Fax. +359 2 68 9102

**Canada:** PHILIPS SEMICONDUCTORS/COMPONENTS,  
Tel. +1 800 234 7381, Fax. +1 800 943 0087

**China/Hong Kong:** 501 Hong Kong Industrial Technology Centre,  
72 Tat Chee Avenue, Kowloon Tong, HONG KONG,  
Tel. +852 2319 7888, Fax. +852 2319 7700

**Colombia:** see South America

**Czech Republic:** see Austria

**Denmark:** Sydhavnsgade 23, 1780 COPENHAGEN V,  
Tel. +45 33 29 3333, Fax. +45 33 29 3905

**Finland:** Sinikalliontie 3, FIN-02630 ESPOO,  
Tel. +358 9 615 800, Fax. +358 9 6158 0920

**France:** 51 Rue Carnot, BP317, 92156 SURESNES Cedex,  
Tel. +33 1 4099 6161, Fax. +33 1 4099 6427

**Germany:** Hammerbrookstraße 69, D-20097 HAMBURG,  
Tel. +49 40 2353 60, Fax. +49 40 2353 6300

**Hungary:** see Austria

**India:** Philips INDIA Ltd, Band Box Building, 2nd floor,  
254-D, Dr. Annie Besant Road, Worli, MUMBAI 400 025,  
Tel. +91 22 493 8541, Fax. +91 22 493 0966

**Indonesia:** PT Philips Development Corporation, Semiconductors Division,  
Gedung Philips, Jl. Buncit Raya Kav.99-100, JAKARTA 12510,  
Tel. +62 21 794 0040 ext. 2501, Fax. +62 21 794 0080

**Ireland:** Newstead, Clonskeagh, DUBLIN 14,  
Tel. +353 1 7640 000, Fax. +353 1 7640 200

**Israel:** RAPAC Electronics, 7 Kehilat Saloniki St, PO Box 18053,  
TEL AVIV 61180, Tel. +972 3 645 0444, Fax. +972 3 649 1007

**Italy:** PHILIPS SEMICONDUCTORS, Via Casati, 23 - 20052 MONZA (MI),  
Tel. +39 039 203 6838, Fax +39 039 203 6800

**Japan:** Philips Bldg 13-37, Kohnan 2-chome, Minato-ku,  
TOKYO 108-8507, Tel. +81 3 3740 5130, Fax. +81 3 3740 5057

**Korea:** Philips House, 260-199 Itaewon-dong, Yongsan-ku, SEOUL,  
Tel. +82 2 709 1412, Fax. +82 2 709 1415

**Malaysia:** No. 76 Jalan Universiti, 46200 PETALING JAYA, SELANGOR,  
Tel. +60 3 750 5214, Fax. +60 3 757 4880

**Mexico:** 5900 Gateway East, Suite 200, EL PASO, TEXAS 79905,  
Tel. +9-5 800 234 7381, Fax +9-5 800 943 0087

**Middle East:** see Italy

**Netherlands:** Postbus 90050, 5600 PB EINDHOVEN, Bldg. VB,  
Tel. +31 40 27 82785, Fax. +31 40 27 88399

**New Zealand:** 2 Wagener Place, C.P.O. Box 1041, AUCKLAND,  
Tel. +64 9 849 4160, Fax. +64 9 849 7811

**Norway:** Box 1, Manglerud 0612, OSLO,  
Tel. +47 22 74 8000, Fax. +47 22 74 8341

**Pakistan:** see Singapore

**Philippines:** Philips Semiconductors Philippines Inc.,  
106 Valero St. Salcedo Village, P.O. Box 2108 MCC, MAKATI,  
Metro MANILA, Tel. +63 2 816 6380, Fax. +63 2 817 3474

**Poland:** Al.Jerozolimskie 195 B, 02-222 WARSAW,  
Tel. +48 22 5710 000, Fax. +48 22 5710 001

**Portugal:** see Spain

**Romania:** see Italy

**Russia:** Philips Russia, Ul. Usatcheva 35A, 119048 MOSCOW,  
Tel. +7 095 755 6918, Fax. +7 095 755 6919

**Singapore:** Lorong 1, Toa Payoh, SINGAPORE 319762,  
Tel. +65 350 2538, Fax. +65 251 6500

**Slovakia:** see Austria

**Slovenia:** see Italy

**South Africa:** S.A. PHILIPS Pty Ltd., 195-215 Main Road Martindale,  
2092 JOHANNESBURG, P.O. Box 58088 Newville 2114,  
Tel. +27 11 471 5401, Fax. +27 11 471 5398

**South America:** Al. Vicente Pinzon, 173, 6th floor,  
04547-130 SÃO PAULO, SP, Brazil,  
Tel. +55 11 821 2333, Fax. +55 11 821 2382

**Spain:** Balmes 22, 08007 BARCELONA,  
Tel. +34 93 301 6312, Fax. +34 93 301 4107

**Sweden:** Kottbygatan 7, Akalla, S-16485 STOCKHOLM,  
Tel. +46 8 5985 2000, Fax. +46 8 5985 2745

**Switzerland:** Allmendstrasse 140, CH-8027 ZÜRICH,  
Tel. +41 1 488 2741 Fax. +41 1 488 3263

**Taiwan:** Philips Semiconductors, 5F, No. 96, Chien Kuo N. Rd., Sec. 1,  
TAIPEI, Taiwan Tel. +886 2 2134 2451, Fax. +886 2 2134 2874

**Thailand:** PHILIPS ELECTRONICS (THAILAND) Ltd.,  
60/14 MOO 11, Bangna Trad Road KM. 3, Bagna, BANGKOK 10260,  
Tel. +66 2 361 7910, Fax. +66 2 398 3447

**Turkey:** Yukari Dudullu, Org. San. Blg., 2.Cad. Nr. 28 81260 Umraniye,  
ISTANBUL, Tel. +90 216 522 1500, Fax. +90 216 522 1813

**Ukraine:** PHILIPS UKRAINE, 4 Patrice Lumumba str., Building B, Floor 7,  
252042 KIEV, Tel. +380 44 264 2776, Fax. +380 44 268 0461

**United Kingdom:** Philips Semiconductors Ltd., 276 Bath Road, Hayes,  
MIDDLESEX UB3 5BX, Tel. +44 208 730 5000, Fax. +44 208 754 8421

**United States:** 811 East Arques Avenue, SUNNYVALE, CA 94088-3409,  
Tel. +1 800 234 7381, Fax. +1 800 943 0087

**Uruguay:** see South America

**Vietnam:** see Singapore

**Yugoslavia:** PHILIPS, Trg N. Pasica 5/v, 11000 BEOGRAD,  
Tel. +381 11 3341 299, Fax.+381 11 3342 553

**For all other countries apply to:** Philips Semiconductors,  
Marketing Communications, Building BE-p, P.O. Box 218, 5600 MD EINDHOVEN,  
The Netherlands, Fax. +31 40 27 24825

**Internet:** <http://www.semiconductors.philips.com>

© Philips Electronics N.V. 2000

SCA 70

All rights are reserved. Reproduction in whole or in part is prohibited without the prior written consent of the copyright owner.

The information presented in this document does not form part of any quotation or contract, is believed to be accurate and reliable and may be changed without notice. No liability will be accepted by the publisher for any consequence of its use. Publication thereof does not convey nor imply any license under patent- or other industrial or intellectual property rights.

Printed in The Netherlands

02/pp52

Date of release: 2000 Sep 07

Document order number: 9397 750 07434

*Let's make things better.*

**Philips**  
Semiconductors



**PHILIPS**